

PROVEN CHUCK WITH SPIRAL RING

The RÖHM geared scroll chucks have already been in use for decades and have proven themselves a thousand times over. The jaws can be quickly adjusted over the entire clamping range by means of the spiral ring. Using the radially arranged drive, the force is transferred to the hardened spiral ring via a bevel gearing and further conducted to the clamping jaws via the spiral.



GEARED SCROLL CHUCKS

The RÖHM geared scroll chucks have proven themselves a thousand times over and have already been used successfully on lathes, rotary tables and dividing attachments for decades. The jaws can be adjusted over the entire clamping range in order to be able to very quickly clamp workpieces with a wide clamping diameter range without offsetting the jaws.

ADVANTAGE AT A GLANCE

- ⊕ Quick jaw adjustment over the entire clamping range
- ⊕ Proven chuck with optimal price/performance ratio
- ⊕ Protection of the machine spindle by means of splash-water edge

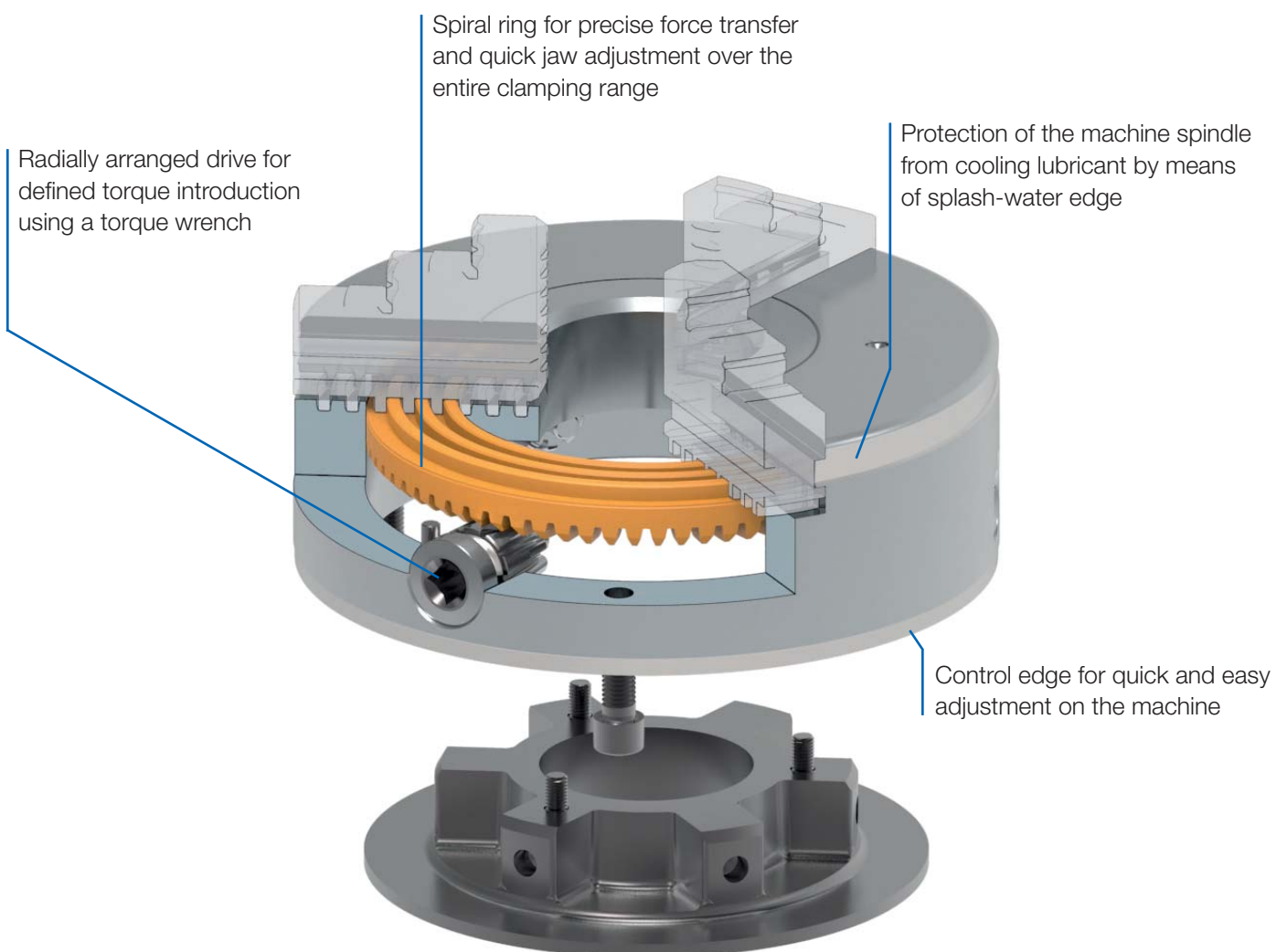

Geared scroll chucks



Geared scroll chucks with independently adjustable jaws

ES

This chuck is used for aligning irregularly shaped workpieces.

Principle of operation

Through a radially arranged drive (1, hardened), the force is transferred via a bevel gearing to a hardened spiral ring (2) and further conducted via the spiral to the base jaws (3, hardened and ground), spindle (4, hardened) and reversible jaws (5, hardened and ground). The position of the workpiece can be adjusted by turning the spindle. Steel body (6), cover (7).

Clamping force transfer system

The jaws can be adjusted over the entire clamping range by turning the key.

Lubrication

To maintain the clamping force, geared scroll chucks must be lubricated regularly. You will find corresponding information in the operating instructions which are enclosed with every chuck. All geared scroll chucks are provided with grease nipples for easy maintenance.

Geared scroll chucks

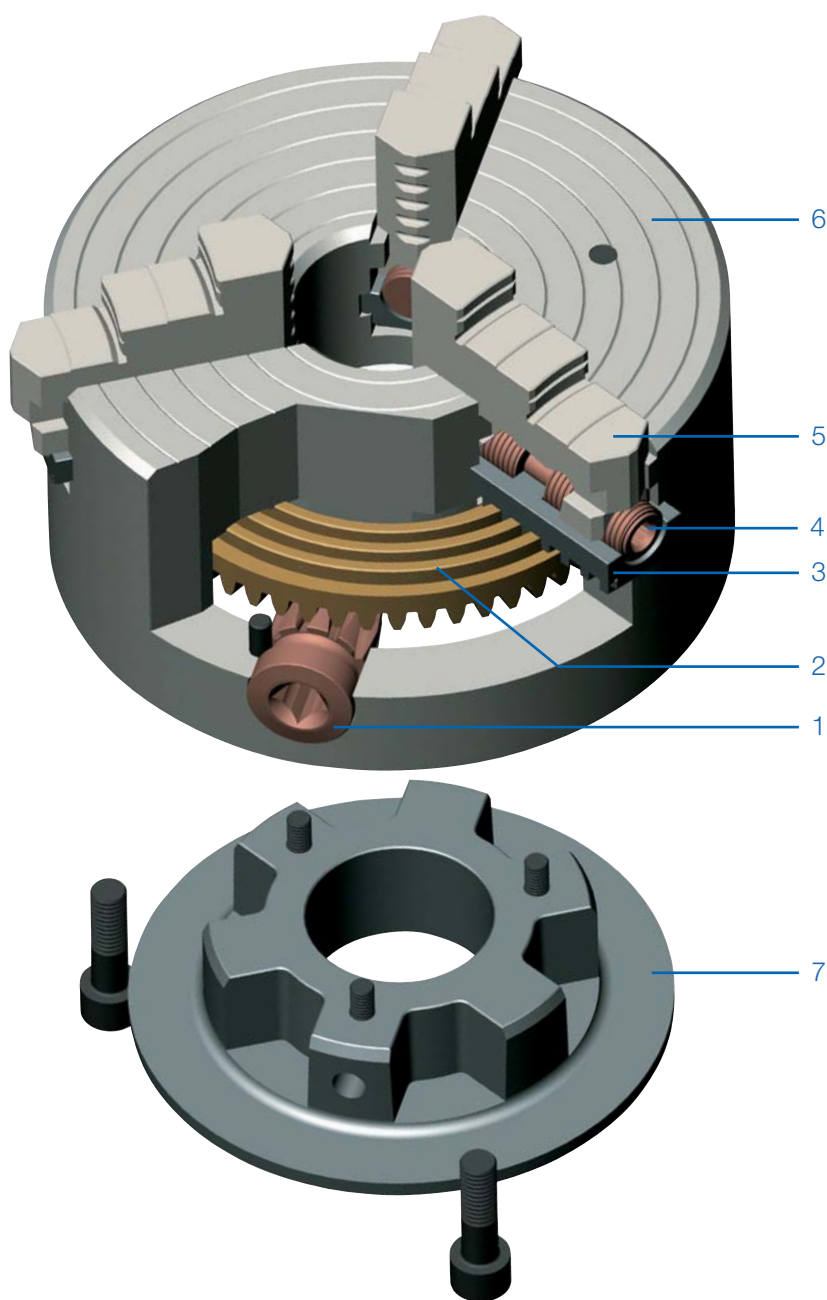

Base jaw GB, hardened and ground



Reversible top jaw UB, hardened and ground



Unstepped jaw BL, unstepped, soft, material 16MnCr5



Geared scroll chucks with independently adjustable jaws

ES - independently adjustable jaws



APPLICATION

Optimized for the machining of irregularly shaped workpieces.

TYPE

Geared scroll chuck in steel design with which irregularly shaped workpieces can be aligned via adjusting spindles. 3-jaw and 4-jaw version.

CUSTOMER BENEFITS

- ⊕ Exact alignment of irregularly shaped workpieces
- ⊕ Jaws centrally clamping and individually adjustable
- ⊕ Die-forged spiral ring, series-balanced and hardened
- ⊕ Jaws in chuck ground out for concentricity

TECHNICAL FEATURES

- With one set each of base and reversible jaws
- Clamping wrench
- Dimensions and mountings to DIN 6351
- Hardened spiral ring
- Die-forged steel body

ES = independently adjustable jaws, steel

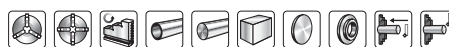

Geared scroll chuck
ES

A09
DIN 6351, cylindrical centre mount, form A

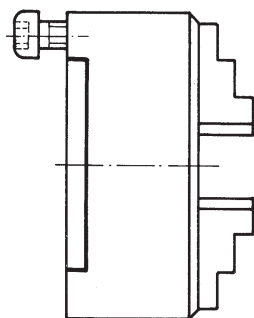

Size	ZA	Through-hole mm	3-jaw chuck steel	4-jaw chuck steel	Torque Nm	Total clamping force kN
160	125	42	111360 ▲	111789 ▲	110	47
200	160	55	111365	111793	140	55
250	200	76	111370	111797	150	63
315	260	103	111375 ▲	111801	180	69
400	330	136	111380 ▲	111805 ▲	240	92
500	420	190	111385 ▲	111809 ▲	260	100
630	545	240	111390 ▲	111813 ▲	280	105

Further sizes and mountings available on request



Geared scroll chucks with independently adjustable jaws

Jaws ES

A09

Reversible jaw UB, hardened, tongue and groove for external and internal clamping, material 16 MnCr5



Chuck Size	3-jaw set	4-jaw set	Jaw length mm	Jaw height mm	Jaw width mm
160	110118	110124	69	50	20
200	139666	139670	85	57,5	24
250	139667	139671	90	67,5	24
315/400	139668	139672	130	79,5	34
500/630	139669	139673	190	95	42

A09

Unstepped jaw BL, unstepped, soft



Chuck Size	3-jaw set	4-jaw set	Jaw length mm	Jaw height mm	Jaw width mm
160	107669	107675	69	50	20
200	139674	139678	85	57,5	24
250	139675	139679	90	67,5	24
315/400	139676	139680	130	79,5	34
500/630	139677	139681	190	95	42

A09

Base jaw GB, hardened, tongue and groove for external and internal clamping, material 16 MnCr5



Chuck Size	3-jaw set	4-jaw set	Jaw length mm	Jaw height mm	Jaw width mm
160	107654	107662	62	15,3	26
200	139682	139686	78	17,8	30
250	139683	139687	86	17,8	30
315	139684	139688	118	22,7	44
400	139685	139689	118	22,7	44
500/630	107659	107667	176	25	54



Geared scroll chucks with independently adjustable jaws

Accessories ES

A09 Base plates for lathe chucks with cylindrical centre mount, DIN 6350

Item no.	Size	Thread
162793	160	6xM10
162401	200	6xM10
163036	250	
133705	315	



A09 Special grease F80 for lathe chucks

For lubrication and conservation of chucking power

Item no.	Design	Contents
308555	Cartridge (DIN 1284) Ø 53.5x235mm	0,5 kg
028975	Tin	1 kg



A09 Adjusting spindle

Item no.	For chuck size
104251 ▲	125
104271 ▲	160
137735 ▲	200
137643 ▲	250
137701 ▲	400/315
137716	500



A09 Adjusting key

Item no.	For chuck size	Square	Hexagon
107444 ▲	125/160	5,5	-
139695 ▲	200/250/315/400	-	8
139696 ▲	500/630	-	12



A09 Scroll

Item no.	Size
101721	125
100303	160
100003	200
100203	250
101552	315
102497	400
162973	500
162964	630



A09 Driving pinion

Item no.	Size	Square
100304	160	10
100005	200	11
100204	250	12
112267	270	12
101553	315	14
105229	350	14
102498	400	17
162974	500	19
162965	630	19



A09 Pinion holder screw

Item no.	Size
100305	160
100006	270
101554	315
102499	400
103300	630



A09 Standard key

Item no.	Size	Square	Length mm
107427	100/110	8	75
107428	125/140	9	80
107429	160	10	90
107430	200/230	11	100
107431	250/270	12	100
107432	315	14	110
107433	350	14	140
107434	400	17	140
107435	500/630	19	150



C15 Grease gun DIN1283

Item no.	Connec-tion	Contents of delivery
329093	M10x1	150 mm nozzle tube bent, needlepoint mouthpiece, top mouthpiece, 300 mm high pressure hose with 4 jaw hydraulics cross mouthpiece





Geared scroll chucks with independently adjustable jaws

Accessories ES

Accessories ES

A09 Safety key with ejector



Item no.	Size	Square	Length mm
154371	100/110	8	130
154372	125/140	9	130
154373	160	10	160
154374	200/230	11	160
154375	250/270	12	160
154376	315	14	200
154377	350	14	200
154378	400	17	250
154379 ▲	500/630	19	250

A09 Elongated safety key with ejector



Item no.	Size	Square	Length mm
154683	125/140	9	170
154685	160	10	180
154687	200/230	11	200
154689	250/270	12	200
154695	315	14	250

A09 Safety adapter with ejector

For actuating the chuck with torque (defined torque introduction)



Item no.	Size	Square	Inch
178566 ▲	80/85	6	3/8
178567 ▲	100/110	8	1/2
178568 ▲	125/140	9	1/2
178569 ▲	160	10	1/2
178570	200/230	11	1/2
178571 ▲	250/270	12	1/2
178572	315/350	14	1/2

A09 Torque wrench



Item no.	Torque Nm	Length mm	Output	Working accuracy
10004116	20-120	435	12,7=1/2"	3%
10004117	60-320	659	12,7=1/2"	3%

C15 Mounting screws

For lathe chucks with direct short-taper, for front mounting



Item no.	Size	Thread	Contents of delivery	Chuck Size	Taper size
233059	74	M10x70	piece	160	5
308436	80	M10x85	piece	200	5
200186	85	M12x85	piece	200	6
234615	100	M10x110	piece	250	5
302215	110	M12x90	piece	250	6
202439	125	M16x90	piece	250	8
316244	140	M12x120	piece	315	6
308439	160	M16x105	piece	315	8
342701	315	M16x130	piece	400	8
698878	350	M20x115	piece	400	11
011528	400	M20x155	piece	500	11
358815	500	M20x170	piece	630	11
202509	630	M24x150	piece	630	15

C15 Set screw with nut, DIN 55021



Item no.	Thread	For taper	Quantity
107453	M10x30	4	3
107455 ▲	M10x35	5	4
107456 ▲	M12x40	6	4
107457 ▲	M16x45	8	4
107458 ▲	M20x55	11	6
127618 ▲	M24x65	15	6

A09 Stud and locknut ISO 702-3 (DIN 55027)



Item no.	Thread	Contents of delivery	For taper	Quantity
107447	M10x34	piece	3	3
107448	M10x39	piece	4	3
107449	M10x43	piece	5	4
107450	M12x50	piece	6	4
107451	M16x60	piece	8	4
107452	M20x75	piece	11	6
125650	M24x90	piece	15	6

A09 Stud for Camlock ASA B 5.9 (DIN 55029) and cylindrical studs



Item no.	Thread	For taper	Quantity
107465 ▲	7/16-20x35	3	3
107466	7/16-20x37	4	3
107467	1/2-20x43	5	6
107468	5/8-18x49	6	6
107469	3/4-16x55,5	8	6
107470	7/8-14x67	11	6
127621 ▲	1-14x76	15	6

A09 Stud for Camlock ISO 702-2 (DIN 55029) and cylindrical studs



Item no.	Thread	For taper	Quantity
178364 ▲	M10x1	3	3
178365	M10x1	4	3
178366 ▲	M12x1	5	6
178367	M16x1,5	6	6
178368 ▲	M20x1,5	8	6
178369 ▲	M22x1,5	11	6
178370 ▲	M24x1,5	15	6
178371	M27x2	20	6



Chuck dimensions ES

Chuck dimensions ES

Cylindrical centre mount DIN 6351

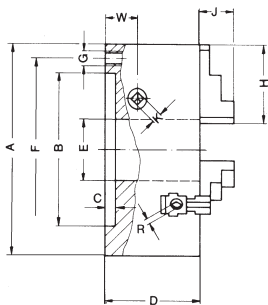

The bore (measure E) could be enlarged (at surcharge)

■ Enlarged bore max.

Size A	100	125	160	200	250	315	400	500	630
BH6	70	95	125	160	200	260	330	420	545
C	3	4	4	4	5	5	5	5	7
D	67	71	80	95,5	100	117	123	145	160
E	20	32	42	55	76	103	136	190	240
E _{max.}	21	33	50	70	92	114	150	210	253
F	83	108	140	176	224	286	362	458	586
G	3xM8	3xM8	3xM10	3xM10	3xM12	3xM16	3xM16	6xM16	6xM16
H	56	56	69	85	90	130	130	190	190
J	22	21	28	32,5	40,6	46,5	47	55	55
K	8	9	10	11	12	14	17	19	19
R*	5,5	5,5	5,5	8	8	8	8	12	12
W	20	20	22,45	25,7	26,5	30	35	38	48
approx. kg	4	6	10	18	29	54	88	145	240

* from Ø 200 hexagon

Max. permissible speeds for chucks ES to DIN 6351

The specified values are only applicable for workpieces not exceeding a specific unbalance of 25 gmm/kg.

Size	Steel body	
	3-Jaw	4-Jaw
100	-	-
125	-	-
160	3200	2850
200	2650	2350
250	2200	1900
315	1400	1220
400	1400	1220
500	880	770
630	750	660

Reversible jaw UB

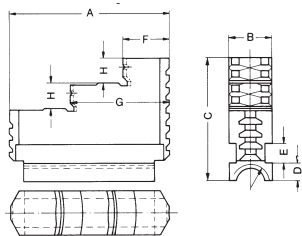

Left-hand thread

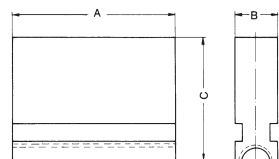

Size	100	125	160	200	250	315	400	500	630
A	56	56	69	85	90	130	130	190	190
B	18	18	20	24	24	34	34	42	42
C	41,5	41,5	50	57,5	67,5	79,5	79,5	95	95
D	8,7	8,7	9,7	9,7	9,7	11,15	11,15	15	15
E	7	7	8	10	10	15	15	15	15
F	17	17	19	25	26	40	40	50	50
G	35	35	43	54	56	85	85	120	120
H	8	8	10	12	14	15	15	20	20
Thread	Tr14x3	Tr14x3	Tr16x4	Tr18x2	Tr18x2	Tr20x2	Tr20x2	Tr26x3	Tr26x3
approx. kg	0,18	0,18	0,3	0,53	0,7	1,7	1,7	3,7	3,7

Chuck dimensions ES



Lever scroll chucks

KRF - actuation by turning the clamping ring

Lever scroll chuck KRF



APPLICATION

3- and 4-jaw chuck for positioning and conveying workpieces, e.g. on measuring machines.

TYPE

Lever scroll chuck in cast iron version.
3-jaw and 4-jaw version.

CUSTOMER BENEFITS

- Easy clamping of the workpiece by turning the clamping ring
- Sizes 125 - 200: incl. 4 setscrews for fine adjustment
- Cast iron body
- Jaws in chuck ground out for concentricity

TECHNICAL FEATURES

- 6 jaw chuck for grinding twist drills on request available

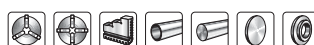

A09

Lever scroll chuck KRF, cylindrical centre mount

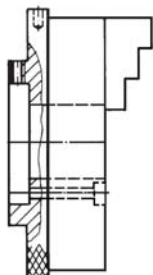

Size	ZA	Through-hole mm	3-jaw chuck with inside and outside jaw	4-jaw chuck with inside and outside jaw	Torque Nm	Total clamping force kN
70	48	16	148793 ¹⁾	148794 ▲	12	2,5
110	75	26	148757	148772	26	3,2
125	70	35	150757	150758 ▲	36	3,5
160	78,5	52	150759	150760 ▲	50	4
200	115	64	150761	150762 ▲	60	4,5

¹⁾ Jaws reversible

Sizes 125 - 200: 4 setscrews for fine adjustment

Further sizes and mountings available on request

Dimensions KRF, cylindrical centre mount

A	B ^{H6}	C	D	F	3-jaws G	4-jaws G	H	J	K	M	Clamping range external	Clamping range internal	Weight ca. kg 3-jaws	Weight ca. kg 4-jaws
70	48	1,5	33	39	3xM6	3xM6	32	13,6	52	72	2-70	23-70	1	1,4
110	75	2	38	62	3xM8	3xM8	48	19	85	112	3-110	33-104	3	3,4
125	70	8	53	56	3xØ6,6	4xØ6,6	52	22,5	83	129	3-125	37-123	4	4,5
160	78,5	8	52	65	3xØ6,6	4xØ6,6	61	26,6	96	164	3-160	39-152	7	7,5
200	115	13	66	84	3xØ9	4xØ9	69	31	147	205	4-200	44-186	13	14

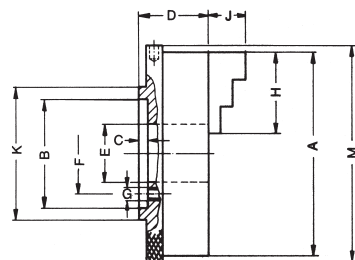

Size 70-100

4 setscrews for fine adjustment

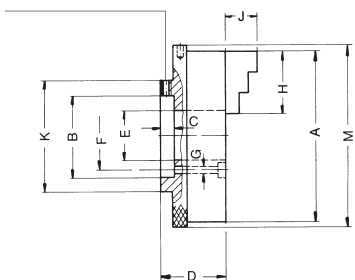



Lever scroll chucks

KRF - on base plate



APPLICATION

3-jaw chuck with base plate for positioning and conveying workpieces, e.g. on measuring machines.

TYPE

Lever scroll chuck in cast iron version.

CUSTOMER BENEFITS

- ⊕ Easy clamping of the workpiece by turning the clamping ring
- ⊕ Sizes 125 - 200: incl. 4 setscrews for fine adjustment
- ⊕ Cast iron body

TECHNICAL FEATURES

- Mounted in the chuck with one set of jaws stepped outward (BB)
- One set of jaws stepped inward (DB)
- Size 70 with reversible jaws
- Mounting screws

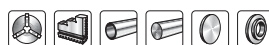

A09

Lever scroll chucks with base plate, 3-jaw-chuck cast iron body

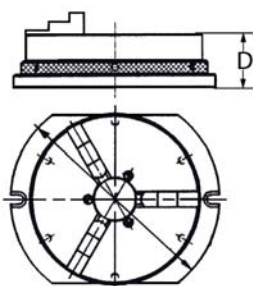

Item no.	Size	Through-hole mm	D mm	Torque Nm	Total clamping force kN
150595 ¹⁾	70	16	46,4	12	2,5
150596	110	26	50	26	3,2
150597▲	125	35	59	36	3,5
150598▲	160	52	59	50	4
150599	200	64	69	60	4,5

¹⁾ Jaws reversible

Further sizes and mountings available on request

Dimensions KRF, cylindrical centre mount

Size	A ₁	B	C	F	G	H	J	K	M	N	O	Clamping range external	Clamping range internal
70	100	70	87	72	32	5	13	21	9	6	60	2-70	23-70
110	140	110	126	112	48	6	13	23	9	8	67,5	3-110	33-104
125	170	125	154	129	52	8	14	32	11	8	81,5	3-125	37-123
160	200	160	184	164	61	10	15	31	11	8	85	3-160	39-152
200	250	200	230	205	69	10	15	39	11	8	100	4-200	44-186

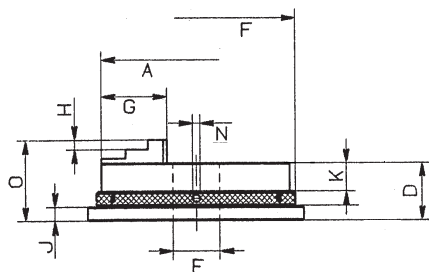



Lever scroll chucks

Jaws KRF

A09

Inside jaw BB, DIN 6350, outward stepped jaw, hardened



Chuck Size	3-jaw set	4-jaw set	Jaw length mm	Jaw height mm	Jaw width mm
70	110154 ¹⁾ ▲	149305▲	32	23	10
110	110156	110064	48	33,5	14
125	110157	110065	52	41,5	18
160	110159	110067	61	47,5	18
200	110160	110068	69	53,5	20

¹⁾ Reversible for use a turning or inside jaw
Additionally or later applied, hardened stepped jaws must be ground out in the chuck.
For jaws which are applied later, send in the chuck.

A09

Outside jaw DB, DIN 6350, inward stepped jaw, hardened



Chuck Size	3-jaw set	4-jaw set	Jaw length mm	Jaw height mm	Jaw width mm
70/110	110166	110074	48	33,5	14
125	110167	110075	52	41,5	18
160	110169	110077	61	47,5	18
200	110170	110078	69	53,5	20

Additionally or later applied, hardened stepped jaws must be ground out in the chuck.
For jaws which are applied later, send in the chuck.

A09

Unstepped jaw BL, DIN 6350, unstepped, soft, material 16MnCr5



Chuck Size	3-jaw set	4-jaw set	Jaw length mm	Jaw height mm	Jaw width mm
70	109114 ¹⁾ ▲	149304▲ ¹⁾	32	23	10
110	107589	107599	48	33,5	14
125	107590	107600	52	41,5	18
160	107592	107602	61	47,5	18
200	107593	107603	69	53,5	20

¹⁾ Reversible

Accessories KRF

A09 Chip guard, piece



Item no.	Size	Contents of delivery
108501	100/110	piece
108502	125	piece
108503	140/160	piece
108504	200	piece

A09 Special grease F80 for lathe chucks

For lubrication and conservation of chucking power



Item no.	Design	Contents
308555	Cartridge (DIN 1284) Ø 53,5x235mm	0,5 kg
028975	Tin	1 kg

C15 Grease gun DIN1283



Item no.	Conne- ction	Contents of delivery
329093	M10x1	150 mm nozzle tube bent, needlepoint mouthpiece, top mouthpiece, 300 mm high pressure hose with 4 jaw hydraulics cross mouthpiece



Notes

Notes



Jaw cutting attachment

BAV



APPLICATION

For turning out unhardened and grinding out hardened jaws. Adjusting jaws reversible and infinitely variably adjustable.

TYPE

Lightweight design.

CUSTOMER BENEFITS

- ⌚ Using the BAV, the chuck can be put into the status it assumes later during workpiece machining (preclamping) within a few seconds
- ⌚ The turned clamping surfaces of the chuck jaws are thus form-fit and exactly concentric in the clamped state
- ⌚ Bypassing a large clamping range

TECHNICAL FEATURES

- Only applicable with base jaws (GB) and top jaws (AB)

Jaw cutting attachment BAV

A09
Jaw cutting attachment for 3-jaw chucks

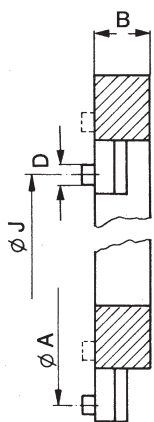

Item no.	Size	For chuck size	Clamping force max. kN	External Ø mm	Inner Ø mm	Overhang distance		B	Thread	Weight approx. kg
						Ø J	Ø A			
220206	0	125	15	153	110	50-115	150-215	20	M5	1,6
220207	1	200	30	176	110	35-125	170-260	31	M8	3,4
220208	2	250	30	215	135	70-140	215-285	31	M8	5
220209	3	250	30	244	162	100-175	240-315	31	M8	5,7
220210	4	315	30	290	208	145-215	290-360	31	M8	6,9
220211 ▲	5	400	40	342	260	160-270	330-440	31	M10	8,5





Geared scroll chucks in steel design

ZS - ZSU - centric clamping

Geared scroll chucks
ZS - ZSU



APPLICATION

Proven geared scroll chuck for use in areas requiring high clamping forces, high concentricity as well as reliable long-term repeatability. For universal use on lathes, rotary tables, dividing units, etc.

TYPE

Geared scroll chucks in steel design. 3-jaw and 4-jaw version.

CUSTOMER BENEFITS

- ⊕ High clamping force
- ⊕ Special flat design for minimum interfering contours
- ⊕ The jaws can be adjusted over the entire clamping range by turning the key. This allows workpieces with different clamping diameters to be quickly clamped
- ⊕ Jaws in chuck ground out for concentricity

TECHNICAL FEATURES

- With one-piece jaws or with base and top jaws
- Steel body and spiral ring die-forged
- Series-balanced and hardened

ZS = centric clamping, steel

ZSU = centric clamping, steel, reversible top jaws

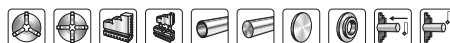

A09
DIN 6350, cylindrical centre mount, form A

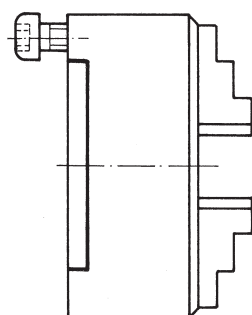

Size	ZA	Through-hole mm	3-jaw chuck with inside and outside jaw	4-jaw chuck with inside and outside jaw	3-jaw chuck with base and reversible top jaw	4-jaw chuck with base and reversible top jaw	Speed max. min ⁻¹	Torque Nm	Total clamping force kN
80	56	19	102513	102505	-	-	7000	30	13
100	70	20	101782	102130	101788	102136 ▲	6300	60	27
125	95	32	101672	106075	101678	106081	5500	80	31
160	125	42	100717	101164	100725	101170 ▲	4600	110	47
200	160	55	100186	100466	100189	100484 ▲	4000	140	55
250	200	76	100533	101030	100541	101036 ▲	3000	150	63
315	260	103	101344	101598	101350	101901 ▲	2300	180	69
400	330	136	102062	102330 ▲	102068 ▲	102336	1800	240	92
500	420	190	102555 ▲	103340	102585 ▲	103346	1300	260	100
630	545	240	102720 ▲	102856	102726	102862	850	280	105
800	710	380	-	-	104913 ▲	104917 ▲	700	300	110
1000	910	460	-	-	104925	104929 ▲	560	450	115
1250	910	550	-	-	104941	104945	450	450	115

Further sizes and mountings available on request
Geared scroll chucks in 6-jaw design available on request

A09
Mounting from front, DIN 6350, cylindrical centre mount

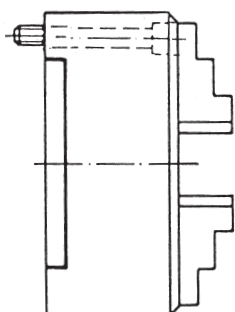

Size	ZA	Through-hole mm	3-jaw chuck with inside and outside jaw	4-jaw chuck with inside and outside jaw	Speed max. min ⁻¹	Torque Nm	Total clamping force kN
125	95	32	120155	124447 ▲	5500	80	31
160	125	42	115568	125802 ▲	4600	110	47
200	160	55	113158	113160	4000	140	55
250	200	76	114304	114306 ▲	3000	150	63
315	260	103	120270	129946 ▲	2300	180	69
400	330	136	123475 ▲	134401 ▲	1800	240	92
500	420	190	127616 ▲	123465 ▲	1300	260	100
630	545	240	128545 ▲	135061 ▲	850	280	105

Further sizes and mountings available on request



Geared scroll chucks in steel design

ZS - ZSU - centric clamping

A09
ISO 702-1 (DIN 55026), DIN 55021, ASA B 5.9, A1/A2 metr.; mounting from front

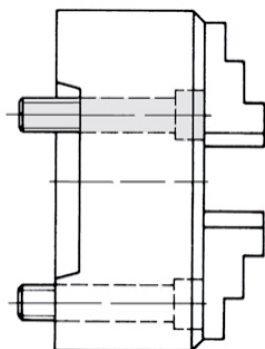

Size	Mount short taper	Through-hole mm	3-jaw chuck with inside and outside jaw	4-jaw chuck with inside and outside jaw	3-jaw chuck with base and reversible top jaw	4-jaw chuck with base and reversible top jaw	Speed max. min ⁻¹	Torque Nm	Total clamping force kN
160	5	42	100753 ¹⁾ ▲	101196▲	100757▲	101199▲	4600	110	47
200	5	42	100168 ¹⁾ ▲	101446▲	100172▲	101452▲	4000	140	55
200	6	55	100173 ¹⁾ ▲	101454▲	100177▲	101460▲	4000	140	55
250	5	76	100571▲	101064▲	100580▲	101073▲	3000	150	63
250	6	55	100567 ¹⁾ ▲	101062▲	100578▲	101071▲	3000	150	63
250	8	76	100569 ¹⁾ ▲	101063▲	100579▲	101072▲	3000	150	63
315	6	103	101376▲	101931▲	101385▲	101937▲	2300	180	69
315	8	76	101377 ¹⁾ ▲	101939▲	101386▲	101945▲	2300	180	69
350	6	103	114643▲	127557▲	127848▲	127850▲	1900	210	74
350	8	76	117319 ¹⁾ ▲	117320▲	127847▲	127849▲	1900	210	74
400	8	136	102226▲	102353▲	102232▲	102359▲	1800	240	92
400	11	125	102234 ¹⁾ ▲	102361▲	102240▲	102367▲	1800	240	92
500	11	190	102562▲	102979▲	102568▲	102985▲	1300	260	100
630	11	190	102768▲	102896▲	102774▲	103002▲	850	280	105
630	15	190	102784 ¹⁾ ▲	103012▲	102790▲	103018▲	850	280	105

¹⁾ Mounting from front in the inner bolt circle

A09
ISO 702-2 (DIN 55029), ASA B 5.9, type D, with studs for Camlock

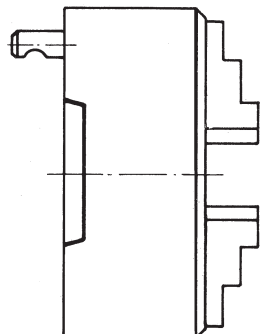

Size	Mount short taper	Through-hole mm	3-jaw chuck with inside and outside jaw	4-jaw chuck with inside and outside jaw	3-jaw chuck with base and reversible top jaw	4-jaw chuck with base and reversible top jaw	Speed max. min ⁻¹	Torque Nm	Total clamping force kN
125	4	32	108895	109208	105870	105872	5500	80	31
160	4	42	108897	109210▲	105882▲	105886▲	4600	110	47
160	5	42	109150▲	109213▲	105898	106302	4600	110	47
200	5	55	109151	109214	106330	106334	4000	140	55
200	6	55	109154	109217	106346▲	106350	4000	140	55
250	6	76	109155	109218	106386▲	106390▲	3000	150	63
250	8	76	109159	109222▲	106402	106406	3000	150	63
315	6	103	109156▲	109219	106442	106446▲	2300	180	69
315	8	103	109160	109223▲	106458▲	106462	2300	180	69
315	11	103	109165	109228	106474	106478	2300	180	69
400	8	136	109161▲	109224	106498	106602	1800	240	92
400	11	136	109166▲	109229	106614	106618	1800	240	92
500	11	190	109167▲	109230▲	103274▲	106646▲	1300	260	100
500	15	190	109170▲	109233▲	103275▲	103271▲	1300	260	100
630	11	192,7	109168▲	109231▲	106658▲	106662▲	850	280	105
630	15	240	109171▲	109234▲	103328▲	106251▲	850	280	105

Further sizes and mountings available on request

A09
ISO 702-3 (DIN 55027), with studs and locknuts, optional DIN 55021 with set screw and nut

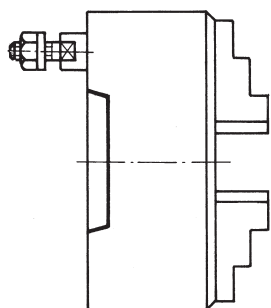

Size	Mount short taper	Through-hole mm	3-jaw chuck with inside and outside jaw	4-jaw chuck with inside and outside jaw	3-jaw chuck with base and reversible top jaw	4-jaw chuck with base and reversible top jaw	Speed max. min ⁻¹	Torque Nm	Total clamping force kN
125	4	32	101692	107015	101695	107021	5500	80	31
160	4	42	100740	101184	100743▲	101187	4600	110	47
160	5	42	100744	101188	100747▲	101191	4600	110	47
200	5	55	100152	100472	100155▲	101420▲	4000	140	55
200	6	55	100156	101422	100159	101428▲	4000	140	55
250	6	76	100555	101050	100564	101059	3000	150	63
250	8	76	100556	101051	100565▲	101060▲	3000	150	63
315	6	103	101364	101919▲	101373▲	101922	2300	180	69
315	8	103	101365	101923▲	101374▲	101926	2300	180	69
315	11	103	101366▲	101927▲	101375▲	101930▲	2300	180	69
400	8	136	102202▲	101876▲	102208	101882	1800	240	92
400	11	136	102210▲	101884▲	102216▲	101890	1800	240	92
500	11	190	102548▲	102971▲	102554▲	102977▲	1300	260	100
500	15	190	102915▲	103227▲	102921▲	103233▲	1300	260	100
630	11	192,7	102752▲	102888▲	102758▲	102894▲	850	280	105
630	15	240	102760▲	103084▲	102766▲	103090▲	850	280	105

Further sizes and mountings available on request



Geared scroll chucks in steel design

Jaws ZS - ZSU

A09

Inside jaw BB, DIN 6350, outward stepped jaw, hardened



Chuck Size	3-jaw set	4-jaw set	Jaw length mm	Jaw height mm	Jaw width mm
80	110155	110063	37	26	12
100	110156	110064	48	33,5	14
125	110157	110065	52	41,5	18
160	110159	110067	61	47,5	18
200	110160	110068	69	53,5	20
250	110161	110069	90	67,5	24
315	110162	110070	130	79,5	34
350/400	110163	110071	130	79,5	34
500/630	110164	110072	190	95	42

Additionally or later applied, hardened stepped jaws must be ground out in the chuck.
For jaws which are applied later, send in the chuck.

Jaws ZS - ZSU

A09

Outside jaw DB, DIN 6350, inward stepped jaw, hardened



Chuck Size	3-jaw set	4-jaw set	Jaw length mm	Jaw height mm	Jaw width mm
80	110165	110073	37	26	12
100	110166	110074	48	33,5	14
125	110167	110075	52	41,5	18
160	110169	110077	61	47,5	18
200	110170	110078	69	53,5	20
250	110171	110079	90	67,5	24
315	110016	110080	130	79,5	34
350/400	110017	110081	130	79,5	34
500/630	110018	110082	190	95	42

Additionally or later applied, hardened stepped jaws must be ground out in the chuck.
For jaws which are applied later, send in the chuck.

A09

Unstepped jaw BL, DIN 6350, unstepped, soft, material 16MnCr5



Chuck Size	3-jaw set	4-jaw set	Jaw length mm	Jaw height mm	Jaw width mm
80	107588	107598	37	26	12
100	107589	107599	48	33,5	14
125	107590	107600	52	41,5	18
160	107592	107602	61	47,5	18
200	107593	107603	69	53,5	20
250	107594	107604	90	67,5	24
315	107595	107605	130	79,5	34
350/400	107596	107644	130	79,5	34
500/630	107597	107645	190	95	42



Geared scroll chucks in steel design

Jaws ZS - ZSU

A09

Base jaw GB, DIN 6350, with fixing screw



Chuck Size	3-jaw set	4-jaw set	Jaw length mm	Jaw width mm
100	107500	107542	46	14
125	107501	107543	55	18
160	107503	107545	65	18
200	107504	107546	78	20
250	107505	107547	92	24
315	107506	107548	108	34
350/400	107507	107549	127	34
500	107508	107550	165	42
630	107509	107551	203	42
800	105272	141616	291	55
1000	105274	141611	329	55
1250	105275	141614	367	55

A09

Reversible top jaws UB, DIN 6350, hardened tongue and groove for external and internal clamping, material 16 MnCr5



Chuck Size	3-jaw set	4-jaw set	Jaw length mm	Jaw height mm	Jaw width mm
100	108045	108053	47	29,5	22
125	108046	108054	56	37,5	26
160	107936	107938	66,7	41,5	28
200	107937	107939	79,5	42,5	30
250	108049	108057	95,3	52,5	36
315	108050	108058	109,5	57,5	42
350/400	108051	108059	127	64,5	42
500/630	108052	108060	127	79,5	50
800	105081	105085	210	89	68
1000/1250	105098	105101	210	110	68

Additionally or later applied, hardened stepped jaws must be ground out in the chuck.
For jaws which are applied later, send in the chuck.

A09

Unstepped top jaw AB, DIN 6350, soft, material 16MnCr5



Chuck Size	3-jaw set	4-jaw set	Jaw length mm	Jaw height mm	Jaw width mm
100	107633	107641	53	30	22,5
125	107634	107642	62	38	26,5
160	108581	108583	74	42	28,5
200	108582	108584	87	43	30,5
250	107637	107579	103	53	36,5
315	107638	107580	120	58	42,5
350/400	107639	107581	137	65	42,5
500/630	107640	107582	140	80	50,5
800	105103	105105	210	89	68
1000/1250	105107	105109	210	110	68



Geared scroll chucks in steel design

Jaws ZS - ZSU

A09

Unstepped jaw BL, special length, soft, material 16MnCr5, DIN 6350



Chuck Size	3-jaw set	4-jaw set	A1 mm	X1 max.	A mm	J mm	X max. mm
200	130031	137073	100	50	69	32,5	19
250	132658	137074	120	56	90	41	26
315	132184	129894	160	70	130	46	40
350/400	137075	130442	160	70	130	42	40
500/630	131540	137076	220	80	190	55	50
200	130033	137077	120	70	69	32,5	19
250	128880	130610	140	76	90	41	26
315	118908	137078	200	110	130	46	40
350/400	137079	137080	200	110	130	42	40
500/630	137081	137082	280	140	190	55	50
315	121367	133691	250	160	130	46	40
350/400	137087	137088	250	160	130	42	40

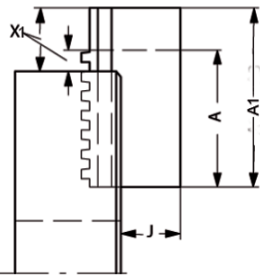

Jaws ZS - ZSU

A09

Unstepped jaw BL, special height, soft, material 16MnCr5, DIN 6350



Chuck Size	3-jaw set	4-jaw set	C1 mm	J1 mm	C mm	J mm
200	125710	132972	80	58,5	54	32,5
250	122188	134796	100	73	68	41
315	132186	137091	110	76	80	46
350/400	137092	131655	110	72	80	42
500/630	137093	137094	150	110	95	55
200	125712	137095	120	98,5	54	32,5
250	122189	130630	130	103	68	41
315	137096	137097	140	106	80	46
350/400	137098	137099	140	102	80	42
500/630	125117	137100	200	160	95	55
200	125714	137101	150	128,5	54	32,5
250	137102	137103	150	123	68	41
315	137104	130340	160	126	80	46
350/400	132879	110109	160	122	80	42

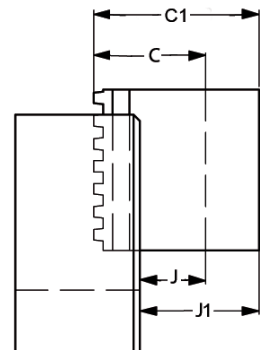



Geared scroll chucks in steel design

Jaws ZS - ZSU

A09

Top jaw AB, special length, soft, material 16MnCr5, DIN 6350

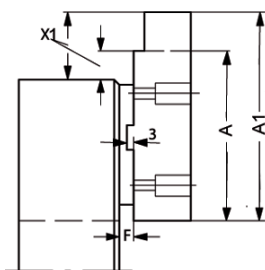

Chuck Size	3-jaw set	4-jaw set	A1 mm	X1 max.	F mm	A mm	X max. mm
200	110086	148139	100	43	6,8	87	30
250	112122	129289	130	63	8	103	36
315	110624	143764	160	76	5,5	120	36
350/400	110626	141277	160	53	8,5	137	30
500/630	103014	103393	170	75	8,5	140	45
200	112120	148657	120	63	6,8	87	30
250	125428	128700	150	83	8	103	36
315	112091	147754	200	116	5,5	120	36
350/400	112118	141263	200	93	8,5	137	30
500/630	110632 ▲	148234	220	125	8,5	140	45
250	104710	146013	180	113	8	103	36
315	112089	147860	250	166	5,5	120	36
350/400	103654	149974	260	153	8,5	137	30
500/630	112127	148235	280	185	8,5	140	45

A09

Top jaw AB, special height, soft, material 16MnCr5, DIN 6350

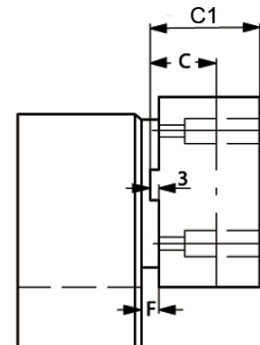

Chuck Size	3-jaw set	4-jaw set	C1 mm	C mm	F mm
200	132155	132181	60	43	6,8
250	119645	135867	70	53	8
315	110435	149975	80	58	5,5
350/400	126385	118373	90	65	8,5
500/630	128590	149985	100	80	8,5
200	128564	149976	80	43	6,8
250	128571	134999	100	53	8
315	110437	129691	110	58	5,5
350/400	110628	135426	120	65	8,5
500/630	110630	149977	130	80	8,5
250	128573	149978	150	53	8
315	128569	141671	150	58	5,5
350/400	128567	139591	160	65	8,5
500/630	128588	140427	160	80	8,5

A09

Top jaw AB, special width and height, soft, material 16MnCr5, DIN 6350

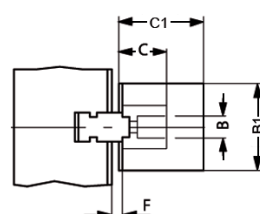

Chuck Size	3-jaw set	4-jaw set	B1 mm	C1 mm	B mm	C mm
200	105057	105061	40	70	30,5	43
250	137090	141338	50	80	36,5	53
315	143053	149979	60	90	42	58
350/400	131567	149980	60	90	42,5	65
500/630	137084	149981	80	110	50,5	80
200	133259	149982	50	80	30,5	43
250	133653	137526	60	90	36,5	53
315	143057	149983	80	110	42	58
350/400	137086	149984	80	110	42,5	65



Geared scroll chucks in steel design

Jaws ZS - ZSU

C15

Mounting bolt for top jaws, bolt 1



Item no.	Size	Thread	Contents of delivery
249299	100	M6x20	piece
236949	125	M8x25	piece
334571	160/200	M8x30	piece
233025	250	M12x40	piece
233026	315	M12x45	piece
220565	350/400	M16x50	piece
249003	500/630	M20x80	piece

C15

Mounting bolt for top jaws, bolt 2



Item no.	Size	Thread	Contents of delivery
216528	100	M6x16	piece
233058	125/160/200	M8x20	piece
227692	250	M12x25	piece
233030	315	M12x30	piece
220564	350/400	M16x35	piece
233047	500/630	M20x40	piece

Jaws ZS - ZSU



Geared scroll chucks in steel design

Accessories ZS - ZSU

A09 Base plates for lathe chucks with cylindrical centre mount, DIN 6350

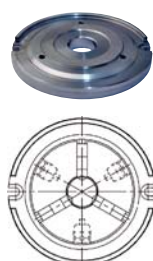

Item no.	Size	Thread
162793	160	6xM10
162401	200	6xM10
163036	250	6xM12
133705	315	6xM16

A09 Unfinished adapter plates for cylindrical mount

The unfinished back plate must be machined and fitted on both machine and chuck side

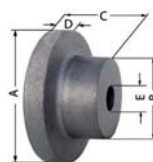

Item no.	Size	Inch	A mm	B mm	C mm	D mm	E mm
017123▲	74	3	80	56	45	15	-
017113▲	80	3 ¼	92	56	47	15	20
017114	100	4	120	80	58	20	25
017115	125	5	135	80	58	20	25
017125▲	140	5 ½	150	80	58	20	25
017116	160	6 ¼	170	80	58	20	30
017117	200	8	210	92	66	22	40
017118▲	250	10	260	105	92	25	50
017119▲	315	12 ½	330	165	100	30	50
017124▲	350	14	365	180	120	30	60

A09 Chip guard, piece



Item no.	Size	Contents of delivery
108500	80/85	piece
108501	100/110	piece
108502	125	piece
108503	140/160	piece
108504	200	piece
108505	250	piece
108506	315/350/400	piece
108508	500/630	piece

A09 Special grease F80 for lathe chucks

For lubrication and conservation of chucking power



Item no.	Design	Contents
308555	Cartridge (DIN 1284) Ø 53.5x235mm	0,5 kg
028975	Tin	1 kg

C15 Grease gun DIN1283



Item no.	Connection	Contents of delivery
329093	M10x1	150 mm nozzle tube bent, needlepoint mouthpiece, top mouthpiece, 300 mm high pressure hose with 4 jaw hydraulics cross mouthpiece

A09 Scroll



Item no.	Size
102521	74
102183	80/85
101754	100
112660	110
101721	125
105827	140
100303	160
100003	200
100203	250
101552	315
105228	350
102497	400
162973	500
162964	630

A09 Driving pinion



Item no.	Size	Square
102522	74	6
102184	80	6
113198	85	6
101755	100	8
112662	110	8
101722	125	9
105828	140	9
100304	160	10
100005	200	11
100204	250	12
112267	270	12
101553	315	14
105229	350	14
102498	400	17
162974	500	19
162965	630	19

A09 Pinion holder screw



Item no.	Size
102523	74
102185	85
100305	100/125/160
100006	200/250
101554	315
102499	400
103300	500/630

A09 Standard key



Item no.	Size	Square	Hexagon	Length mm
006325	74	-	6	55
107426	80/85	6	-	62
107427	100/110	8	-	75
107428	125/140	9	-	80
107429	160	10	-	90
107430	200/230	11	-	100
107431	250/270	12	-	100
107432	315	14	-	110
107433	350	14	-	140
107434	400	17	-	140
107435	500/630	19	-	150



Geared scroll chucks in steel design

Accessories ZS - ZSU

Accessories ZS - ZSU

A09 Safety key with ejector



Item no.	Size	Square	Length mm
154370 ▲	80/85	6	110
154371	100/110	8	130
154372	125/140	9	130
154373	160	10	160
154374	200/230	11	160
154375	250/270	12	160
154376	315	14	200
154377	350	14	200
154378	400	17	250
154379 ▲	500/630	19	250

A09 Elongated safety key with ejector



Item no.	Size	Square	Length mm
154683	125/140	9	170
154685	160	10	180
154687	200/230	11	200
154689	250/270	12	200
154695	315	14	250

A09 Safety adapter with ejector

For actuating the chuck with torque (defined torque introduction)



Item no.	Size	Square	Inch
178566 ▲	80/85	6	3/8
178567 ▲	100/110	8	1/2
178568 ▲	125/140	9	1/2
178569 ▲	160	10	1/2
178570	200/230	11	1/2
178571 ▲	250/270	12	1/2
178572	315/350	14	1/2
178573 ▲	400	17	1/2
178574 ▲	500/630/700/800	19	3/4
178575 ▲	1000/1250	24	3/4

A09 Torque wrench



Item no.	Torque Nm	Length mm	Output	Working accuracy
10004116	20-120	435	12,7=1/2"	3%
10004117	60-320	659	12,7=1/2"	3%

C15 Mounting screws

For cylindrical centre rim



Item no.	Size	Thread	Contents of delivery
249299	74-85	M6x20	piece
334571	100-140	M8x30	piece
249301	160-230	M10x35	piece
233025	250-270	M12x40	piece
220565	315-350	M16x50	piece
229183	400-630	M16x60	piece

C15 Mounting screws

For lathe chucks with direct short-taper, for front mounting



Item no.	Size	Thread	Contents of delivery	Chuck Size	Taper size
302195	74	M10x55	piece	160	5
200184	80	M10x65	piece	200	5
233006	85	M12x65	piece	200	6
233075	100	M10x90	piece	250	5
216549	110	M12x70	piece	250	6
302194	125	M16x70	piece	250	8
242954	140	M12x100	piece	315	6
358816	160	M16x85	piece	315	8
243665	200/230	M12x130	piece	350	6
236516	315	M16x110	piece	400	8
615744	350	M20x95	piece	400	11
010210	400	M20x130	piece	500	11
328925	500	M20x145	piece	630	11
367648	630	M24x125	piece	630	15

A09 Set screw with nut, DIN 55021



Item no.	Thread	For taper	Quantity
107453	M10x30	4	3
107455 ▲	M10x35	5	4
107456 ▲	M12x40	6	4
107457 ▲	M16x45	8	4
107458 ▲	M20x55	11	6
127618 ▲	M24x65	15	6

A09 Stud for Camlock ISO 702-2 (DIN 55029) and cylindrical studs



Item no.	Thread	For taper	Quantity
178364 ▲	M10x1	3	3
178365	M10x1	4	3
178366 ▲	M12x1	5	6
178367	M16x1,5	6	6
178368 ▲	M20x1,5	8	6
178369 ▲	M22x1,5	11	6
178370 ▲	M24x1,5	15	6
178371	M27x2	20	6



Geared scroll chucks in steel design

Accessories ZS - ZSU

A09 Stud and locknut ISO 702-3 (DIN 55027)



Item no.	Thread	Contents of delivery	For taper	Quantity
107447	M10x34	piece	3	3
107448	M10x39	piece	4	3
107449	M10x43	piece	5	4
107450	M12x50	piece	6	4
107451	M16x60	piece	8	4
107452	M20x75	piece	11	6
125650	M24x90	piece	15	6
130636	M24x100	piece	20	6

A09 Stud for Camlock ASA B 5.9 (DIN 55029) and cylindrical studs



Item no.	Thread	For taper	Quantity
107465 ▲	7/16-20x35	3	3
107466	7/16-20x37	4	3
107467	1/2-20x43	5	6
107468	5/8-18x49	6	6
107469	3/4-16x55,5	8	6
107470	7/8-14x67	11	6
127621 ▲	1-14x76	15	6
130637 ▲	1 1/2-12x89	20	6



Geared scroll chucks in cast iron design

ORANGE LINE

Orange Line - centric clamping

APPLICATION

Proven geared scroll chuck made of special cast iron for use in areas requiring high clamping forces, high concentricity as well as reliable long-term repeatability. For universal use on lathes, rotary tables, dividing units, etc.

TYPE

Geared scroll chucks in cast iron design. Special flat design with direct mounting. 3-jaw and 4-jaw version.

CUSTOMER BENEFITS

- ⊕ Optimal price/performance ratio
- ⊕ Special flat design for minimum interfering contours
- ⊕ The jaws can be adjusted over the entire clamping range by turning the key. This allows workpieces with different clamping diameters to be quickly clamped
- ⊕ Jaws in chuck ground out for concentricity

TECHNICAL FEATURES

- With one set each of one-piece outward- and inward stepped jaws
- Vibration-damping body made of special cast iron
- Spiral ring die-forged as well as balanced and hardened

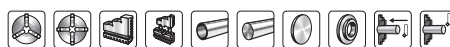

Geared scroll chucks - Orange Line

A09
DIN 6350, cylindrical centre mount, form A

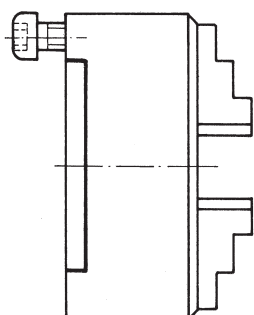

Size	ZA	Through-hole mm	3-jaw chuck with inside and outside jaw	4-jaw chuck with inside and outside jaw	Speed max. min ⁻¹	Torque Nm	Total clamping force kN
100	70	20	101781	102129	4500	60	27
125	95	32	101628	106074	4000	80	31
160	125	42	100300	100325	3600	110	47
200	160	55	100000	100465	3000	140	55
250	200	76	100200	100834	2500	150	63
315	260	103	101248	101567	2000	180	69

A09
Mounting from front, DIN 6350, cylindrical centre mount

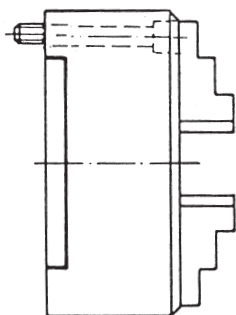

Size	ZA	Through-hole mm	3-jaw chuck with inside and outside jaw	4-jaw chuck with inside and outside jaw	Speed max. min ⁻¹	Torque Nm	Total clamping force kN
125	95	32	116304▲	103053▲	4000	80	31
160	125	42	115566▲	115570▲	3600	110	47
200	160	55	109127▲	111339▲	3000	140	55
250	200	76	114301▲	127916▲	2500	150	63
315	260	103	109128▲	120743▲	2000	180	69



Geared scroll chucks in cast iron design

Jaws Orange Line

A09

Inside jaw BB, DIN 6350, outward stepped jaw, hardened



Chuck Size	3-jaw set	4-jaw set	Jaw length mm	Jaw height mm	Jaw width mm
100	110156	110064	48	33,5	14
125	110157	110065	52	41,5	18
160	110159	110067	61	47,5	18
200	110160	110068	69	53,5	20
250	110161	110069	90	67,5	24
315	110162	110070	130	79,5	34

Additionally or later applied, hardened stepped jaws must be ground out in the chuck.
For jaws which are applied later, send in the chuck.

A09

Outside jaw DB, DIN 6350, inward stepped jaw, hardened



Chuck Size	3-jaw set	4-jaw set	Jaw length mm	Jaw height mm	Jaw width mm
100	110166	110074	48	33,5	14
125	110167	110075	52	41,5	18
160	110169	110077	61	47,5	18
200	110170	110078	69	53,5	20
250	110171	110079	90	67,5	24
315	110016	110080	130	79,5	34

Additionally or later applied, hardened stepped jaws must be ground out in the chuck.
For jaws which are applied later, send in the chuck.

A09

Unstepped jaw BL, DIN 6350, unstepped, soft, material 16MnCr5



Chuck Size	3-jaw set	4-jaw set	Jaw length mm	Jaw height mm	Jaw width mm
100	107589	107599	48	33,5	14
125	107590	107600	52	41,5	18
160	107592	107602	61	47,5	18
200	107593	107603	69	53,5	20
250	107594	107604	90	67,5	24
315	107595	107605	130	79,5	34

A09

Base jaw GB, DIN 6350, with fixing screw



Chuck Size	3-jaw set	4-jaw set	Jaw length mm	Jaw width mm
100	107500	107542	46	14
125	107501	107543	55	18
160	107503	107545	65	18
200	107504	107546	78	20
250	107505	107547	92	24
315	107506	107548	108	34

A09

Reversible top jaws UB, DIN 6350, hardened tongue and groove for external and internal clamping, material 16 MnCr5



Chuck Size	3-jaw set	4-jaw set	Jaw length mm	Jaw height mm	Jaw width mm
100	108045	108053	47	29,5	22
125	108046	108054	56	37,5	26
160	107936	107938	66,7	41,5	28
200	107937	107939	79,5	42,5	30
250	108049	108057	95,3	52,5	36
315	108050	108058	109,5	57,5	42

Additionally or later applied, hardened stepped jaws must be ground out in the chuck.
For jaws which are applied later, send in the chuck.

Jaws Orange Line



Geared scroll chucks in cast iron design

Jaws Orange Line

A09

Unstepped top jaw AB, DIN 6350 soft, material 16MnCr5



Chuck Size	3-jaw set	4-jaw set	Jaw length mm	Jaw height mm	Jaw width mm
100	107633	107641	53	30	22,5
125	107634	107642	62	38	26,5
160	108581	108583	74	42	28,5
200	108582	108584	87	43	30,5
250	107637	107579	103	53	36,5
315	107638	107580	120	58	42,5

Jaws Orange Line

A09

Unstepped jaw BL, special length, soft, material 16MnCr5, DIN 6350



Chuck Size	3-jaw set	4-jaw set	A1 mm	X1 max.	A mm	J mm	X max. mm
200	130031	137073	100	50	69	32,5	19
250	132658	137074	120	56	90	41	26
315	132184	129894	160	70	130	46	40
200	130033	137077	120	70	69	32,5	19
250	128880	130610	140	76	90	41	26
315	118908	137078	200	110	130	46	40
315	121367	133691	250	160	130	46	40

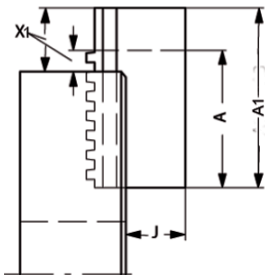

A09

Unstepped jaw BL, special height, soft, material 16MnCr5, DIN 6350



Chuck Size	3-jaw set	4-jaw set	C1 mm	J1	C mm	J mm
200	125710	132972	80	58,5	54	32,5
250	122188	134796	100	73	68	41
315	132186	137091	110	76	80	46
200	125712	137095	120	98,5	54	32,5
250	122189	130630	130	103	68	41
315	137096	137097	140	106	80	46
200	125714	137101	150	128,5	54	32,5
250	137102	137103	150	123	68	41
315	137104	130340	160	126	80	46

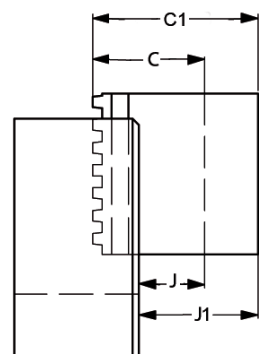



Geared scroll chucks in cast iron design

Jaws Orange Line

A09

Top jaw AB, special length, soft, material 16MnCr5, DIN 6350



Chuck Size	3-jaw set	4-jaw set	A1 mm	X1 max.	F mm	A mm	X max. mm
200	110086	148139	100	43	6,8	87	30
250	112122	129289	130	63	8	103	36
315	110624	143764	160	76	5,5	120	36
200	112120	148657	120	63	6,8	87	30
250	125428	128700	150	83	8	103	36
315	112091	147754	200	116	5,5	120	36
250	104710	146013	180	113	8	103	36
315	112089	147860	250	166	5,5	120	36

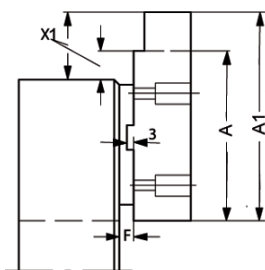

A09

Top jaw AB, special height, soft, material 16MnCr5, DIN 6350



Chuck Size	3-jaw set	4-jaw set	C1 mm	C mm	F mm
200	132155	132181	60	43	6,8
250	119645	135867	70	53	8
315	110435	149975	80	58	5,5
200	128564	149976	80	43	6,8
250	128571	134999	100	53	8
315	110437	129691	110	58	5,5
250	128573	149978	150	53	8
315	128569	141671	150	58	5,5

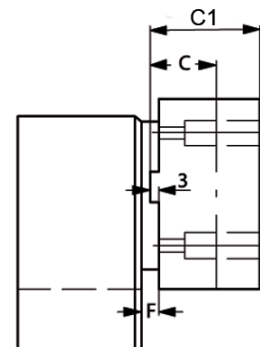

A09

Top jaw AB, special width and height, soft, material 16MnCr5, DIN 6350



Chuck Size	3-jaw set	4-jaw set	B1 mm	C1 mm	B mm	C mm
200	105057	105061	40	70	30,5	43
250	137090	141338	50	80	36,5	53
315	143053	149979	60	90	42	58
200	133259	149982	50	80	30,5	43
250	133653	137526	60	90	36,5	53
315	143057	149983	80	110	42	58

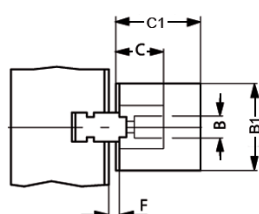



Geared scroll chucks in cast iron design

Jaws Orange Line

C15

Mounting bolt for top jaws, bolt 1



Item no.	Size	Thread	Contents of delivery
249299	100	M6x20	piece
236949	125	M8x25	piece
334571	160/200	M8x30	piece
233025	250	M12x40	piece
233026	315	M12x45	piece

C15

Mounting bolt for top jaws, bolt 2



Item no.	Size	Thread	Contents of delivery
216528	100	M6x16	piece
233058	125/160/200	M8x20	piece
227692	250	M12x25	piece
233030	315	M12x30	piece

Jaws Orange Line



Geared scroll chucks in cast iron design

Accessories Orange Line

A09 Base plates for lathe chucks with cylindrical centre mount, DIN 6350



Item no.	Size	Thread
162793	160	6xM10
162401	200	6xM10
163036	250	
133705	315	

A09 Unfinished adapter plates for cylindrical mount

The unfinished back plate must be machined and fitted on both machine and chuck side

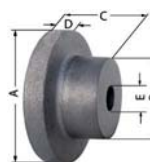

Item no.	Size	Inch	A mm	B mm	C mm	D mm	E mm
017114	100	4	120	80	58	20	25
017115	125	5	135	80	58	20	25
017116	160	6 ¼	170	80	58	20	30
017117	200	8	210	92	66	22	40
017118▲	250	10	260	105	92	25	50

A09 Chip guard, piece



Item no.	Size	Contents of delivery
108501	100/110	piece
108502	125	piece
108503	140/160	piece
108504	200	piece
108505	250	piece
108506	315/350/400	piece

A09 Special grease F80 for lathe chucks

For lubrication and conservation of chucking power



Item no.	Design	Contents
308555	Cartridge (DIN 1284) Ø 53.5x235mm	0,5 kg
028975	Tin	1 kg

A09 Scroll



Item no.	Size
101754	100
112660	110
101721	125
105827	140
100303	160
100003	200
100203	250
101552	315

A09 Driving pinion



Item no.	Size	Square
101755	100	8
112662	110	8
101722	125	9
105828	140	9
100304	160	10
100005	200	11
100204	250	12
112267	270	12
101553	315	14
105229	350	14

A09 Pinion holder screw



Item no.	Size
100305	100/125/160
100006	200/250
101554	315

A09 Standard key



Item no.	Size	Square	Length mm
107427	100/110	8	75
107428	125/140	9	80
107429	160	10	90
107430	200/230	11	100
107431	250/270	12	100
107432	315	14	110

C15 Grease gun DIN1283



Item no.	Connec-tion	Contents of delivery
329093	M10x1	150 mm nozzle tube bent, needlepoint mouthpiece, top mouthpiece, 300 mm high pressure hose with 4 jaw hydraulics cross mouthpiece



Geared scroll chucks in cast iron design

Accessories Orange Line

A09 Safety key with ejector



Item No.	Size	Square	Length mm
154371	100/110	8	130
154372	125/140	9	130
154373	160	10	160
154374	200/230	11	160
154375	250/270	12	160
154376	315	14	200

A09 Elongated safety key with ejector



Item No.	Size	Square	Length mm
154683	125/140	9	170
154685	160	10	180
154687	200/230	11	200
154689	250/270	12	200
154695	315	14	250

A09 Safety adapter with ejector

For actuating the chuck with torque (defined torque introduction)



Item No.	Size	Square	Inch
178567 ▲	100/110	8	1/2
178568 ▲	125/140	9	1/2
178569 ▲	160	10	1/2
178570	200/230	11	1/2
178571 ▲	250/270	12	1/2
178572	315/350	14	1/2

A09 Torque wrench



Item No.	Torque Nm	Length mm	Output	Working accuracy
10004116	20-120	435	12,7=1/2"	3%
10004117	60-320	659	12,7=1/2"	3%

C15 Mounting screws

For cylindrical centre rim



Item No.	Size	Thread	Contents of delivery
334571	100-140	M8x30	piece
249301	160-230	M10x35	piece
233025	250-270	M12x40	piece
220565	315-350	M16x50	piece

C15 Mounting screws

For lathe chucks with direct short-taper, for front mounting



Item No.	Size	Thread	Contents of delivery	Chuck Size	Taper size
233075	100	M10x90	piece	250	5
216549	110	M12x70	piece	250	6
302194	125	M16x70	piece	250	8
242954	140	M12x100	piece	315	6
358816	160	M16x85	piece	315	8
243665	200/230	M12x130	piece	350	6
236516	315	M16x110	piece	400	8

A09 Set screw with nut DIN 55021



Item No.	Thread	For taper	Quantity
107453	M10x30	4	3
107455 ▲	M10x35	5	4
107456 ▲	M12x40	6	4
107457 ▲	M16x45	8	4
107458 ▲	M20x55	11	6
127618 ▲	M24x65	15	6

A09 Stud for Camlock ISO 702-2 (DIN 55029) and cylindrical studs



Item No.	Thread	For taper	Quantity
178364 ▲	M10x1	3	3
178365	M10x1	4	3
178366 ▲	M12x1	5	6
178367	M16x1,5	6	6
178368 ▲	M20x1,5	8	6
178369 ▲	M22x1,5	11	6
178370 ▲	M24x1,5	15	6
178371	M27x2	20	6

A09 Stud and locknut ISO 702-3 (DIN 55027)



Item No.	Thread	Contents of delivery	For taper	Quantity
107447	M10x34	piece	3	3
107448	M10x39	piece	4	3
107449	M10x43	piece	5	4
107450	M12x50	piece	6	4
107451	M16x60	piece	8	4
107452	M20x75	piece	11	6
125650	M24x90	piece	15	6
130636	M24x100	piece	20	6

A09 Stud for Camlock ASA B 5.9 (DIN 55029) and cylindrical studs



Item No.	Thread	For taper	Quantity
107465 ▲	7/16-20x35	3	3
107466	7/16-20x37	4	3
107467	1/2-20x43	5	6
107468	5/8-18x49	6	6
107469	3/4-16x55,5	8	6
107470	7/8-14x67	11	6
127621 ▲	1-14x76	15	6
130637 ▲	1 1/2-12x89	20	6

Accessories Orange Line



Notes

Notes



Lathe and grinding chucks

ZS Hi-Tru - with fine adjustment

Lathe and grinding chucks ZS Hi-Tru



APPLICATION

Optimized for machining workpieces which must be produced with **maximum concentricity**. Can be universally used, but is especially advantageous on turning and grinding machines as well as dividing units.

TYPE

Lathe and grinding chuck in steel design with which the workpiece can be adjusted very sensitively to the desired concentricity via 3 tangentially arranged adjusting spindles.

CUSTOMER BENEFITS

- ⊕ Radial fine adjustment for maximum concentricity
- ⊕ Repeatability 0.015 mm
- ⊕ Adjusting accuracy within 0.005 mm
- ⊕ Precision adjustment without opening the mounting screws
- ⊕ Jaws in chuck ground out for concentricity

TECHNICAL FEATURES

- With one set outside jaws and one set inside jaws
- Hardened adjusting spindles as well as their support surfaces
- Hardened spiral ring
- Steel take-up flange

ZS Hi-Tru = centric clamping, steel, maximum precision

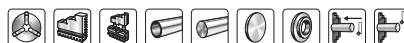

A09

ZS Hi-Tru, with one set outward stepped jaws and one set inward stepped jaws, DIN 6350, cylindrical centre mount, form A

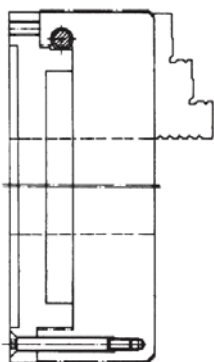

Item no.	Size	ZA	Through-hole mm	Speed max. min ⁻¹	Torque Nm	Total clamping force kN
180259 ▲	80	56	19	7000	30	13
180261	100	70	20	6300	60	27
180263	125	95	32	5500	80	31
180265	160	125	42	4600	110	47
180267	200	160	55	4000	140	55
180269	250	200	76	3000	150	63
180271	315	260	103	2300	180	69

On request from size 125 with 6-jaws or with short-taper mount to ISO 702-3 (DIN 55027) or ISO 702-2 (DIN 55029) Camlock
Further sizes and mountings available on request

A09

ZS Hi-Tru, with special seal for grinding machines, DIN 6350, cylindrical centre mount, form A

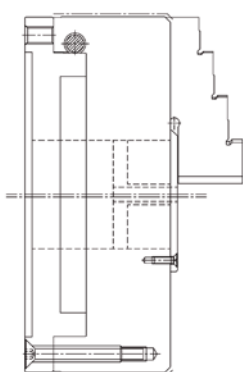

Item no.	Size	ZA	Through-hole mm	Speed max. min ⁻¹	Torque Nm	Total clamping force kN
180273 ▲	80	56		5000	30	13
180275 ▲	100	70		4500	60	27
180277 ▲	125	95	7	4000	80	31
180279 ▲	160	125	7	3600	110	47
180281 ▲	200	160	8	3000	140	55
180283 ▲	250	200	10	2500	150	63
180285 ▲	315	260	16	2000	180	69

On request from size 125 with 6-jaws or with short-taper mount to ISO 702-3 (DIN 55027) or ISO 702-2 (DIN 55029) Camlock



Lathe and grinding chucks

ZS Hi-Tru - with fine adjustment

Dimensions ZS Hi-Tru, DIN 6350, cylindrical centre mount, Form A

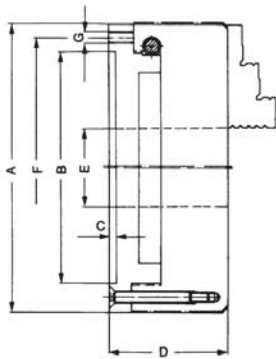

Size A	Inch	B ^{+0,02}	C	D	F	G	SW	Weight
ZS Hi-Tru, with 1 set each outward or inward stepped jaws								
80	3 ^{1/4}	56	3	50,5	67	3xM6	4	1,7
100	4	70	3	63	83	3xM8	5	3,6
125	5	95	4	72	108	3xM8	5	5,6
160	6 ^{1/4}	125	4	81	140	3xM10	6	10
200	8	160	4	89,5	176	3xM10	6	17,2
250	10	200	5	102	224	3xM12	8	34,5
315	12 ^{1/2}	260	5	122	286	3xM16	8	57,5

Size A	Inch	B ^{+0,02}	C	D	F	G	SW	Weight
ZS Hi-Tru, with special seal for grinding machines								
80	3 ^{1/4}	56	3	50,5	67	3xM6	4	1,7
100	4	70	3	63	83	3xM8	5	3,6
125	5	95	4	72	108	3xM8	5	5,6
160	6 ^{1/4}	125	4	81	140	3xM10	6	10
200	8	160	4	89,5	176	3xM10	6	17,2
250	10	200	5	102	224	3xM12	8	34,5
315	12 ^{1/2}	260	5	122	286	3xM16	8	57,5

Lathe and grinding chucks ZS Hi-Tru

Fine adjustment

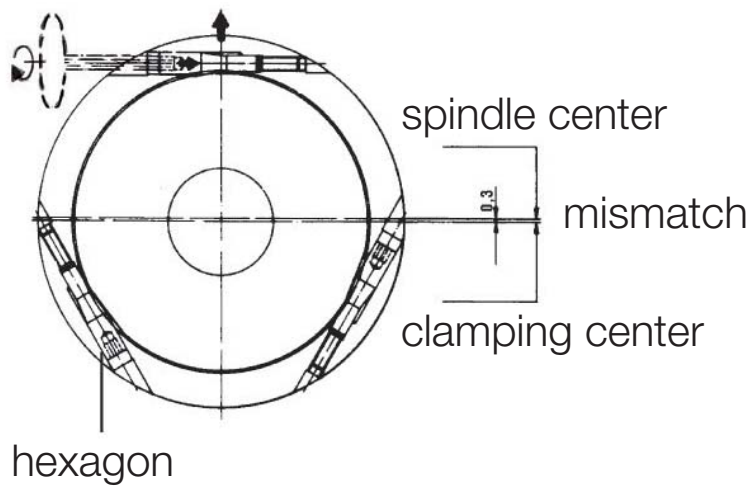

Video functioning ZS Hi-Tru

Jaws ZS Hi-Tru

A09
Inside jaw BB, DIN 6350, outward stepped jaw, hardened



Item no.	Chuck Size	Number of jaws	Contents of delivery	Jaw length mm	Jaw height mm	Jaw width mm
110155	80	3	set	37	26	12
110156	100	3	set	48	33,5	14
110157	125	3	set	52	41,5	18
110159	160	3	set	61	47,5	18
110160	200	3	set	69	53,5	20
110161	250	3	set	90	67,5	24
110162	315	3	set	130	79,5	34

Additionally or later applied, hardened stepped jaws must be ground out in the chuck.
For jaws which are applied later, send in the chuck.

A09
Outside jaw DB, DIN 6350, inward stepped jaw, hardened



Item no.	Chuck Size	Number of jaws	Contents of delivery	Jaw length mm	Jaw height mm	Jaw width mm
110165	80	3	set	37	26	12
110166	100	3	set	48	33,5	14
110167	125	3	set	52	41,5	18
110169	160	3	set	61	47,5	18
110170	200	3	set	69	53,5	20
110171	250	3	set	90	67,5	24
110016	315	3	set	130	79,5	34

Additionally or later applied, hardened stepped jaws must be ground out in the chuck.
For jaws which are applied later, send in the chuck.

A09
Unstepped jaw BL, DIN 6350, unstepped, soft, material 16MnCr5



Item no.	Chuck Size	Number of jaws	Contents of delivery	Jaw length mm	Jaw height mm	Jaw width mm
107588	80	3	set	37	26	12
107589	100	3	set	48	33,5	14
107590	125	3	set	52	41,5	18
107592	160	3	set	61	47,5	18
107593	200	3	set	69	53,5	20
107594	250	3	set	90	67,5	24
107595	315	3	set	130	79,5	34

A09
Base jaw GB, DIN 6350, with fixing screw



Item no.	Chuck Size	Number of jaws	Contents of delivery	Jaw length mm	Jaw width mm
107500	100	3	set	46	14
107501	125	3	set	55	18
107503	160	3	set	65	18
107504	200	3	set	78	20
107505	250	3	set	92	24
107506	315	3	set	108	34

A09
Reversible top jaws UB, DIN 6350, hardened tongue and groove for external and internal clamping, material 16 MnCr5



Item no.	Chuck Size	Number of jaws	Contents of delivery	Jaw length mm	Jaw height mm	Jaw width mm
108045	100	3	set	47	29,5	22
108046	125	3	set	56	37,5	26
107936	160	3	set	66,7	41,5	28
107937	200	3	set	79,5	42,5	30
108049	250	3	set	95,3	52,5	36
108050	315	3	set	109,5	57,5	42

Additionally or later applied, hardened stepped jaws must be ground out in the chuck.
For jaws which are applied later, send in the chuck.



Lathe and grinding chucks

Jaws ZS Hi-Tru

A09

Unstepped top jaw AB DIN 6350, soft, material 16MnCr5



Item no.	Chuck Size	Number of jaws	Contents of delivery	Jaw length mm	Jaw height mm	Jaw width mm
107633	100	3	set	53	30	22,5
107634	125	3	set	62	38	26,5
108581	160	3	set	74	42	28,5
108582	200	3	set	87	43	30,5
107637	250	3	set	103	53	36,5
107638	315	3	set	120	58	42,5

A09

Unstepped jaw BL, special length, soft, material 16MnCr5, DIN 6350



Item no.	Chuck Size	A1 mm	X1 max.	A	J	X max.
130031	200	100	50	69	32,5	19
132658	250	120	56	90	41	26
132184	315	160	70	130	46	40
130033	200	120	70	69	32,5	19
128880	250	140	76	90	41	26
118908	315	200	110	130	46	40
121367	315	250	160	130	46	40

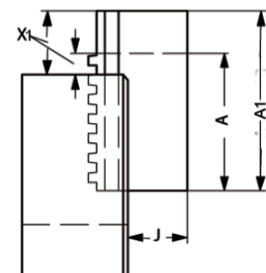

A09

Unstepped jaw BL, special height, soft, material 16MnCr5, DIN 6350



Item no.	Chuck Size	C1	J1	C	J
125710	200	80	58,5	54	32,5
122188	250	100	73	68	41
132186	315	110	76	80	46
125712	200	120	98,5	54	32,5
122189	250	130	103	68	41
137096	315	140	106	80	46
125714	200	150	128,5	54	32,5
137102	250	150	123	68	41
137104	315	160	126	80	46

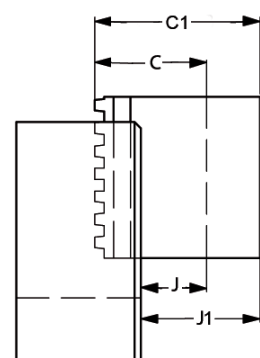

Jaws ZS Hi-Tru

Jaws ZS Hi-Tru

A09
Top jaw AB, special length, soft, material 16MnCr5, DIN 6350



Item no.	Chuck Size	A1 mm	X1 max.	F	A	X max.
110086	200	100	43	6,8	87	30
112122	250	130	63	8	103	36
110624	315	160	76	5,5	120	36
112120	200	120	63	6,8	87	30
125428	250	150	83	8	103	36
112091	315	200	116	5,5	120	36
104710	250	180	113	8	103	36
112089	315	250	166	5,5	120	36

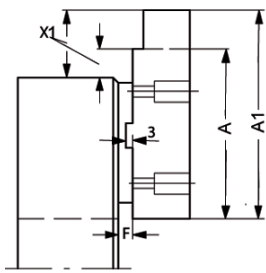

Jaws ZS Hi-Tru

A09
Top jaw AB, special height, soft, material 16MnCr5, DIN 6350



Item no.	Chuck Size	C1	C	F
132155	200	60	43	6,8
119645	250	70	53	8
110435	315	80	58	5,5
128564	200	80	43	6,8
128571	250	100	53	8
110437	315	110	58	5,5
128573	250	150	53	8
128569	315	150	58	5,5

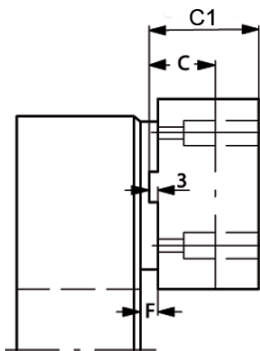

A09
Top jaw AB, special width and height, soft, material 16MnCr5, DIN 6350



Item no.	Chuck Size	B1	C1	B	C
105057	200	40	70	30,5	43
137090	250	50	80	36,5	53
143053	315	60	90	42	58
133259	200	50	80	30,5	43
133653	250	60	90	36,5	53
143057	315	80	110	42	58

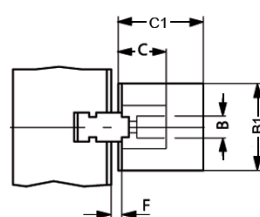



Lathe and grinding chucks

Jaws ZS Hi-Tru

C15

Mounting bolt for top jaws, bolt 1



Item no.	Size	Thread	Contents of delivery
249299	100	M6x20	piece
236949	125	M8x25	piece
334571	160/200	M8x30	piece
233025	250	M12x40	piece
233026	315	M12x45	piece

C15

Mounting bolt for top jaws, bolt 2



Item no.	Size	Thread	Contents of delivery
216528	100	M6x16	piece
233058	125/160/200	M8x20	piece
227692	250	M12x25	piece
233030	315	M12x30	piece



Jaws ZS Hi-Tru



Lathe and grinding chucks

Accessories ZS Hi-Tru

Accessories ZS Hi-Tru

A09 Base plates for lathe chucks with cylindrical centre mount, DIN 6350

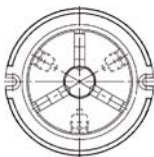

Item no.	Size	Thread
162793	160	6xM10
162401	200	6xM10
163036	250	
133705	315	

A09 Chip guard, piece



Item no.	Size	Contents of delivery
108500	80/85	piece
108501	100/110	piece
108502	125	piece
108503	140/160	piece
108504	200	piece
108505	250	piece
108506	315/350/400	piece

C15 Special grease F80 for lathe chucks For lubrication and conservation of chucking power



Item no.	Design	Contents
308555	Cartridge (DIN 1284) Ø 53.5x235mm	0,5 kg
028975	Tin	1 kg

C15 Scroll



Item no.	Size
102183	80/85
101754	100
101721	125
100303	160
100003	200
100203	250
101552	315

A09 Driving pinion



Item no.	Size	Hexagon
178473	100	9
178474 ▲	110	9
178475	125	10
178476 ▲	140	10
178477	160	11
178478	200	12
178480	250	14
178482	315	17

A09 Pinion holder screw



Item no.	Size
102185	85
100305	100/125/160
100006	200/250
101554	315

A09 Standard key



Item no.	Size	Square	Length mm
107426	80/85	6	62
107427	100/110	8	75
107428	125/140	9	80
107429	160	10	90
107430	200/230	11	100
107431	250/270	12	100
107432	315	14	110

A09 Safety key with ejector



Item no.	Size	Square	Length mm
154370 ▲	80/85	6	110
154371	100/110	8	130
154372	125/140	9	130
154373	160	10	160
154374	200/230	11	160
154375	250/270	12	160
154376	315	14	200

C15 Grease gun DIN1283



Item no.	Connec-tion	Contents of delivery
329093	M10x1	150 mm nozzle tube bent, needlepoint mouthpiece, top mouthpiece, 300 mm high pressure hose with 4 jaw hydraulics cross mouthpiece



Lathe and grinding chucks

Accessories ZS Hi-Tru

A09 Elongated safety key with ejector



Item no.	Size	Square	Length mm
154683	125/140	9	170
154685	160	10	180
154687	200/230	11	200
154689	250/270	12	200
154695	315	14	250

A09 Safety adapter with ejector

For actuating the chuck with torque (defined torque introduction)



Item no.	Size	Square	Inch
178566 ▲	80/85	6	3/8
178567 ▲	100/110	8	1/2
178568 ▲	125/140	9	1/2
178569 ▲	160	10	1/2
178570	200/230	11	1/2
178571 ▲	250/270	12	1/2
178572	315/350	14	1/2

A26 Torque wrench



Item no.	Torque Nm	Length mm	Output	Working accuracy
10004116	20-120	435	12,7=1/2"	3%
10004117	60-320	659	12,7=1/2"	3%

A26 Mounting screws

For cylindrical centre rim



Item no.	Size	Thread	Contents of delivery
249299	74-85	M6x20	piece
334571	100-140	M8x30	piece
249301	160-230	M10x35	piece
233025	250-270	M12x40	piece
220565	315-350	M16x50	piece



Chuck dimensions ZS - ZSU and Orange Line

Chuck dimensions ZS - ZSU and Orange Line

For mounting on dividing heads and other attachments from the front, the lathe chucks with a cylindrical centre mount can also be supplied pre-drilled (at surcharge) G₁, it is also possible to enlarge the bore (measure E, at surcharge).

Cylindrical centre mount DIN 6350

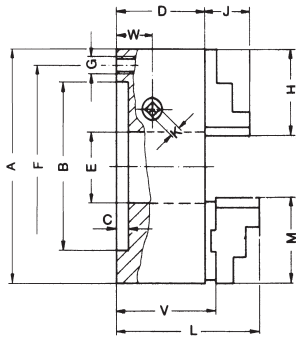

Enlarged bore max.

Size A	74	80	85	100	110	125	140	160	200	250	315	350	400	500	630
B ^{H6}	56	56	60	70	80	95	105	125	160	200	260	290	330	420	545
C	2,5	3	3	3	3	4	4	4	4	5	5	6	5	5	7
D	32,5	39,5	39,5	50	50	56	60	65	73,5	82	95	100	105	120	135
E	15	19	19	20	27	32	40	42	55	76	103	115	136	190	240
E _{max}	-	-	-	21	-	33	43	50	70	92	114	120	150	210	253
F	63	67	72	83	95	108	120	140	176	224	286	318	362	458	586
G	3xM6	3xM6	3xM6	3xM8	3xM8	3xM8	3xM8	3xM10	3xM10	3xM12	3xM16	3xM16	3xM16	6xM16	6xM16
G ₁	-	-	-	-	-	3xØ9*	-	3xØ10,5	3xØ11	3xØ14	3xØ14	-	3xØ18	6xØ18	6xØ18
H	32	37	37	48	48	52	61	61	69	90	130	130	130	190	190
J	14	14	14	18	18	22,5	22,5	26	32,5	40	46	45	43	54,5	54,5
K	6 ¹⁾	6	6	8	8	9	9	10	11	12	14	14	17	19	19
L	-	-	-	80,5	-	95,5	106	108	119,6	139,6	155	168,5	171,5	201,5	216,5
M	-	-	-	47	47	56	66,7	66,7	79,5	95	109,5	127	127	127	127
V	-	-	-	53,6	53,6	61	67,7	69,7	80,2	89,9	100,4	110,4	113,4	128,4	143,3
W	13	14,5	14,5	18	18	20	21	22,45	25,7	26,5	30	34	35	38	48
approx. kg.	1	1,3	1,9	2,9	3,4	4,5	5,8	8,2	14,6	25,7	44,2	56	80	126	208

G₁ = Mounting from front

* 4-jaw = 4 x Ø 9

Chuck dimensions

Cylindrical centre mount with front mounting

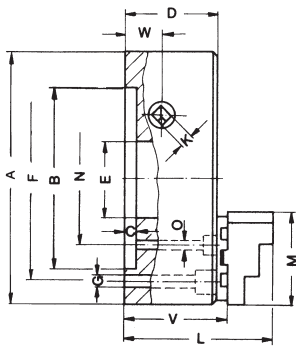

Enlarged bore max.

Size	ØA	700	800	1000	1250
B		610	710	910	910
C ²⁾		7 ^{+0,03}	7 ^{+0,03}	7 ^{+0,03}	7 ^{+0,03}
D		147	147	157	157
E		310	380	460	550
E _{max}		330	420	580	580
F		660	760	950	950
3-Jaw	G	6xØ22	6xØ22	6xØ26	6xØ26
4-Jaw	G	8xØ22	8xØ22	8xØ26	6xØ26
	K	19	19	24	24
	L	240,6	240,6	269,6	269,6
	M	210	210	210	210
	N	360	460	610	610
3-Jaw	O	6xØ18	6xØ18	6xØ18	6xØ18
4-Jaw	O	4xØ18	4xØ18	4xØ18	6xØ18
	V	158	158	166	166
	W	48	48	53	53
	ca. kg	280	350	590	850

1) Hexagon

2) Adaptor plate dimension 7_{±0,03}

Position of fixing screws and pinions on lathe chucks with cylindrical centre mount sizes 74-630 (size 350 on request)

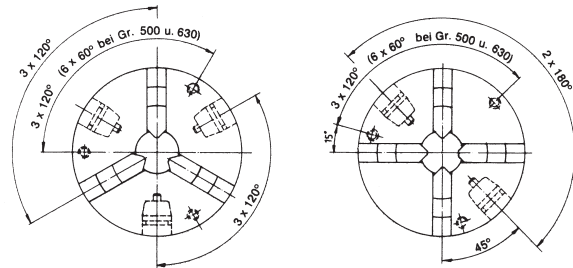

Short taper mount

DIN 55021 with setscrews and locknuts



DIN 55027 with studs and nuts

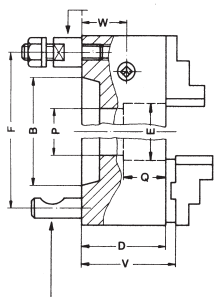

Size	A	100	125	140	160	200
Taper size		3	3	4	3	4
B		53,9	53,9	63,5	53,9	63,5
D		75	69	69	74	74
E		20	32	32	40	40
DIN	F	75	75	85	75	85
Caml.	F	70,6	70,6	82,5	70,6	82,5
	P	-	-	-	-	-
	Q	-	-	-	-	-
	V	78,3	73,7	73,7	81,7	81,7
	W	43	33	33	35	35
Mounting holes	DIN	3	3	3	3	4
		3	3	3	3	3
	ca. kg	4	5,5	7	8,5	15,5

1) 50 with Camlock, other dimensions in the table on the top

DIN 55029 with studs for Camlock



Chuck dimensions ZS - ZSU und Orange Line

Chuck dimensions ZS - ZSU and Orange Line

Short taper mount

DIN 55021
with setscrews and locknuts

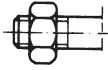

DIN 55027
with studs and nuts

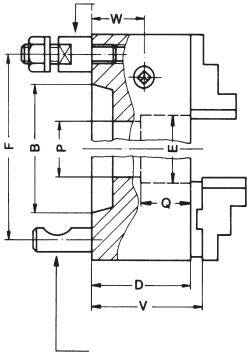

DIN 55029
with studs for Camlock

Size A	250				315				350			400		
Taper size	4	5	6	8	5	6	8	11	6	8	11	6	8	11
B	63,5	82,5	106,4	139,7	82,5	106,4	139,7	196,9	106,4	139,7	196,9	106,4	139,7	196,6
D	83	83	83	83	96	96	96	104	122	122	122	106	106	106
E	60,7	76	76	76	79,6	103	103	103	103	115	115	103	136	136
F	85	82,5	104,8	133,4	171,4	104,8	133,4	171,4	235	133,4	171,4	235	133,4	171,4
P	60,7	-	-	-	79,6	-	-	-	103	-	-	103	-	-
Q	40,5	-	-	-	49	-	-	-	81	-	-	54	-	-
V	90,9	90,9	90,9	90,9	101,4	101,4	101,4	109,4	127,4	127,4	127,4	114,4	114,4	114,4
W	27,5	27,5	27,5	27,5	31	31	31	39	56	56	56	36	36	36
Mounting holes	DIN 3	4	4	4	DIN 4	4	4	6	DIN 4	4	6	DIN 4	4	6
	Caml. 3	6	6	6	Caml. 6	6	6	6	Caml. 6	6	6	Caml. 6	6	6
approx. kg	30				50				71			84		

Size A	500			630		700		800		1000		1250	
Taper size	8	11	15	11	15	11	15	15	20	15	20	15	20
B	139,7	196,9	285,8	196,9	285,8	196,9	285,8	285,8	412,8	285,8	412,8	285,8	412,8
D	122	122	122	137	137	149	149	149	149	159	159	159	159
E	136	190	190	192,7	240	310	310	380	380	460	460	550	550
F	171,4	235	330,2	235	330,2	235	330,2	330,2	463,6	330,2	463,6	330,2	463,6
P	136	-	-	192,7	-	192,7	281,2	281,2	-	281,2	407,5	281,2	407,5
Q	61	-	-	63	-	76	76	76	-	85	85	85	85
V	130,4	130,4	130,4	145,3	145,3	160	160	160	160	168	168	168	168
W	40	40	40	50	50	50	50	50	50	55	55	55	55
Mounting holes	DIN 4	6	6	DIN 6	6	DIN 6	6	DIN 6	6	DIN 6	6	DIN 6	6
	Caml. 6	6	6	Caml. 6	6	Caml. 6	6	Caml. 6	6	Caml. 6	6	Caml. 6	6
approx. kg	150			225		280		350		590		850	

All other dimensions should be taken from the table about chucks with cylindrical centre mount

Short taper mount

DIN 55026
Mounting from front

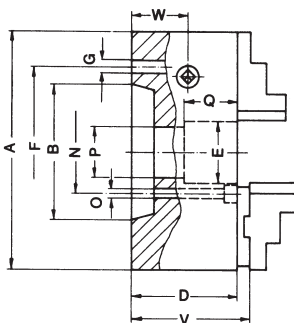

Size A	160	200		250			315		350		400	
Taper size	5	5	6	5	6	8	6	8	6	8	8	11
B	82,5	82,5	106,4	82,5	106,4	139,7	106,4	139,7	106,4	139,7	139,7	196,9
D	66	74,5	74,5	83	83	83	96	96	122	122	106	106
E	42	42	55	76	55	76	103	76	103	76	136	125
F ²⁾	-	-	-	104,8	-	-	133,4	-	133,4	-	171,4	-
G	-	-	-	11 ¹⁾	-	-	14	-	14	-	18	-
N ³⁾	61,9	61,9	82,6	-	82,6	111,1	-	111,1	-	111,1	-	165,1
O	11 ¹⁾	11 ¹⁾	14	-	14	18	-	18	-	18	-	22
V	70,7	81,2	81,2	90,9	90,9	90,9	101,4	101,4	127,4	127,4	114,4	114,4
W	23,45	26,7	26,7	275	275	275	31	31	56	56	36	36
Mounting holes	*	3	6	*	3	6	*	6	*	6	*	6
	**	4	4	**	4	4	**	4	**	4	**	4
approx. kg	8	14,5		25			44,5		71		82	

Size ØA	500	630		700		800		1000		1250	
Taper Size	11	11	15	11	15	11	20	15	20	15	20
B	196,9	196,9	285,9	196,9	285,9	196,9	285,9	412,8	285,9	412,8	285,9
D	122	137	137	149	149	149	149	149	159	159	159
E	190	190	190	310	285	380	380	380	460	505	550
F ²⁾	235	235	-	235	330,2	235	330,2	463,6	330,2	463,6	330,2
G	22	22	-	22	26	22	26	26	26	26	26
N ³⁾	-	-	247,6	-	-	-	-	-	-	-	-
O	-	-	26	-	-	-	-	-	-	-	-
P	-	-	-	193	281,2	193	281,2	-	281,2	407,5	281,2
Q	-	-	-	76	76	76	76	-	85	85	85
V	130,4	145,3	145,3	159,9	159,9	159,9	159,9	159,9	168	168	168
W	40	50	60	50	50	50	50	50	55	55	55
Mounting holes	*	3	6	*	6	6	*	6	*	8	8
	**	4	8	**	8	8	**	8	**	8	8
approx. kg	139	220		295		350		590		850	

1) 12 with ASA B 5.9 inch thread
 2) For DIN 55026 Form A and B; DIN 55021 Form A and B; ASA B 5.9 A1/A2
 3) For DIN 55026 Form B; ASA B 5.9 A1/B1 * 3-Jaw ** 4-Jaw



Chuck dimensions ZS - ZSU and Orange Line

Chuck dimensions ZS - ZSU and Orange Line

External chucking

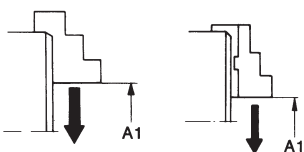

Chucking capacities of jaw steps (standard values)

Size	74	80	85	100	110	125	140	160	200	250
A1 (BB)	2-24	2-30	2-30	3-38	3-42	3-53	3-53	4-72	4-100	5-122
A2 (DB)	2-24	2-30	2-30	3-38	3-42	3-53	3-53	3-72	4-100	5-122
A3 (DB)	23-46	27-55	27-55	38-71	39-77	39-89	47-97	47-116	56-152	73-190
A4 (DB)	45-68	52-80	52-80	70-100	70-100	75-125	91-140	91-160	104-200	131-250
max. swing dia.	88	104	104	128	138	157	174	194	238	302
Jaw movement	11	14	14	15	19	25	25	34	48	58

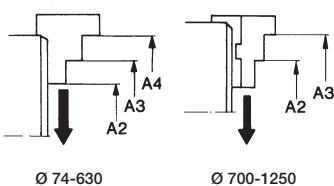

Size	315	350	400	500	630	700	800	1000	1250
A1	6-135	20-180	20-200	35-260	50-350	110-350	150-450	250-600	320-600
A2	6-135	20-180	20-200	35-260	50-350	280-672	325-853	425-1070	490-1150
A3	96-225	110-270	110-300	140-360	190-490	356-748	400-928	500-1150	564-1224
A4	186-315	200-350	200-400	280-500	330-630	-	-	-	-
max. swing dia.	395	440	480	600	730	1000	1170	1390	1476
Jaw movement	64	80	100	110	150	120	150	175	140

Internal chucking

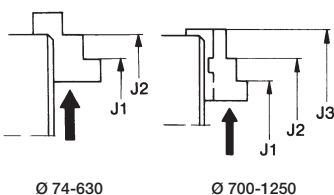

Size	74	80	85	100	110	125	140	160	200	250
J1	23-46	25-53	26-53	33-66	33-71	37-87	39-89	39-107	44-140	59-165
J2	45-68	50-78	50-78	65-94	65-104	73-123	83-132	83-152	92-186	119-236

Size	315	350	400	500	630	700	800	1000	1250
J1	96-224	100-260	100-300	135-355	150-450	212-648	251-855	356-1080	426-1162
J2	186-305	190-350	190-390	275-460	290-590	290-758	326-930	430-1150	500-1236
J3	-	-	-	-	-	526-922	566-1094	660-1314	740-1400

Clamping ranges for lathe chucks with individual adjustable jaws (ES) are in approximate conformity with the above values. They are valid for 3- and 4-jaw chucks and lathe chucks with reversible jaws.

Do not exceed maximum chucking ranges.

Max. permissible speeds for ZS - ZSU, Orange Line, ZS Hi-Tru to DIN 6350

The maximum permissible speed has been fixed so that 1/3 of the gripping force is still available as residual gripping force if the maximum gripping is applied and the chuck is fitted with its heaviest jaws. The jaws may not project beyond the outside diameter of the chuck. The chuck must be in perfect condition. The speed limit for chucks with cast iron bodies is based on the permissible peripheral speed for cast iron. The specification DIN 6386 Part 1 shall be observed.

Size	3 and 4 jaws	
	Cast iron body	Steel body
74	5000	-
80	5000	7000
100	4500	6300
125	4000	5500
140	3700	5000
160	3600	4600
200	3000	4000
250	2500	3000
315	2000	2300
350	1700	1900
400	1600	1800
500	1000	1300
630	800	850
700	650	800
800	600	700
1000	480	560
1250	380	450

Clamping force 3 jaw chuck ZS - ZSU, Orange Line, ZS Hi-Tru to DIN 6350

The clamping force is sum total of all jaw forces acting radially on the stationary workpiece. The clamping forces are approximate values. To obtain the specified clamping forces, the chuck must be in a perfect condition and lubricated with F 80 lubricant recommended by RÖHM.

Size	Torque key	Total clamping force
74	30	11
80	30	13
100	60	27
125	80	31
140	90	40
160	110	47
200	140	55
250	150	63
315	180	69
350	210	74
400	240	92
500	260	100
630	280	105
700	280	105
800	300	110
1000	450	115
1250	450	115



Jaw dimensions ZS - ZSU, Orange Line, ZS Hi-Tru

Jaw dimensions ZS - ZSU, Orange Line, ZS Hi-Tru

Outward stepped jaw (inside jaw) **BB**

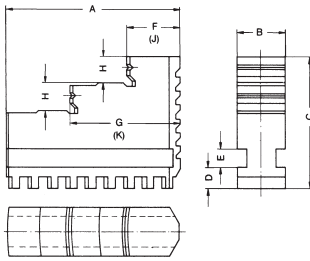

Dimensions F and G apply to outward stepped jaws **BB**
Dimensions J and K apply to inward stepped jaws **DB**

Size	74 ¹⁾	80/85	100/110	125	140	160	200	250	315	350/400	500/630	
A	32	37	48	52	61	61	69	90	130	130	190	
B	10	12	14	18	18	18	20	24	34	34	42	
C	23	26	33,5	41,5	41,5	47,5	53,5	67,5	79,5	79,5	95	
D	4,7	4,8	6,3	7,3	8,3	8,3	8,3	10,3	11,3	11,3	14,9	
E	4	4,5	6	7	7	7	8	10	15	15	15	
F	10	12	15	17	18	18	20	27	41,5	41,5	50	
G	21	24,5	31	35	40	40	44	57	86,5	86,5	120	
H	5	6	6	8	8	10	10	14	15	15	20	
J	-	12	14	16	17	17	19	26	40	40	50	
K	-	24,5	30	34	39	39	43	56	85	85	120	
Jaw approx. kg	BB	0,03	0,05	0,1	0,2	0,22	0,25	0,3	0,7	1,8	1,8	3,8
	BL	0,05	0,08	0,15	0,27	0,32	0,38	0,52	1	2,4	2,4	5,2

Unstepped jaw, soft (block jaw) **BL**

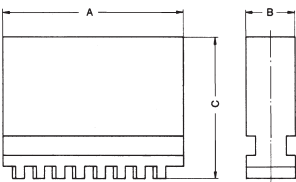

1) Reversible jaws

Base jaw **GB**

Ø 100-400

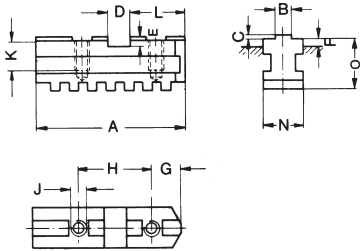

Ø 500-630

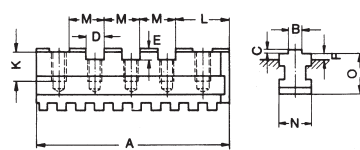

Size	100/110	125	140	160	200	250	315	350/400	500	630
A	46	55	65	65	78	92	108	127	165	203
B-0,05	7,94	7,94	7,94	7,94	7,94	12,7	12,7	12,7	12,7	12,7
C	2,5	3,1	3,1	3,1	3,1	3,1	3,1	3,1	3,1	3,1
D ^{+0,01}	9,5	12,68	12,68	12,68	12,68	19,03	19,03	19,03	19,03	19,03
E	6	7,6	7,6	7,6	7,6	7,6	7,6	10,8	10,8	10,8
F	3,4	4,8	7,8	4,8	6,8	8	5,5	10,5 ²⁾	8,5	8,5
G	12	13	15,8	15,8	19	22,2	25,4	28,5	28,5	28,5
H	24	32	38,1	38,1	44,45	54	63,5	76,2	38,1	38,1
J	metr. M6 UNC 1/4"-20	M8 5/16"-18	M8 3/8"-16	M8 3/8"-16	M8 3/8"-16	M12 1/2"-13	M12 1/2"-13	M16 5/8"-11	M20 3/4"-10	M20 3/4"-10
K	12	14,5	16	16	20	25	29	33	33	33
L	19,25	22,6	28,5	28,5	34,9	39,7	47,6	57,1	57,1	57,1
M	-	-	-	-	-	-	-	-	38,1	38,1
N	14	18	18	18	20	24	34	34	42	42
O	19,5	24	27	27	28	35	40	45	49	49
Grooves	1	1	1	1	1	1	1	1	2	3
Tapped holes	2	2	2	2	2	2	2	2	4	5
Jaw approx. kg	0,06	0,12	0,17	0,17	0,22	0,4	0,78	1	1,72	2,1

Ø 700-1250

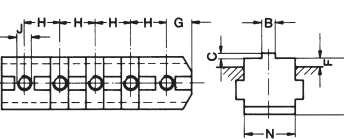

Size	700	800	1000	1250
A	253	291	329	367
B-0,05	12,7	12,7	12,7	12,7
C	3,1	3,1	3,1	3,1
D ^{+0,01}	19,03	19,03	19,03	19,03
E	10,8	10,8	10,8	10,8
F	11	11	9	9
G	28,5	28,5	28,5	28,5
H	38,1	38,1	38,1	38,1
J	metr. M20 UNC 3/4"-10	M20 3/4"-10	M20 3/4"-10	M20 3/4"-10
K	37	37	37	37
L	57,1	57,1	57,1	57,1
M	38,1	38,1	38,1	38,1
N	55	55	55	55
O	62	62	62	62
Grooves	4	5	6	7
Tapped holes	6	7	8	9
Jaw approx. kg	6,2	7,1	8	9

1) Reversible jaws

2) Size



Jaw dimensions ZS - ZSU, Orange Line, ZS Hi-Tru

Jaw dimensions ZS - ZSU, Orange Line, ZS Hi-Tru

Reversible top jaw UB

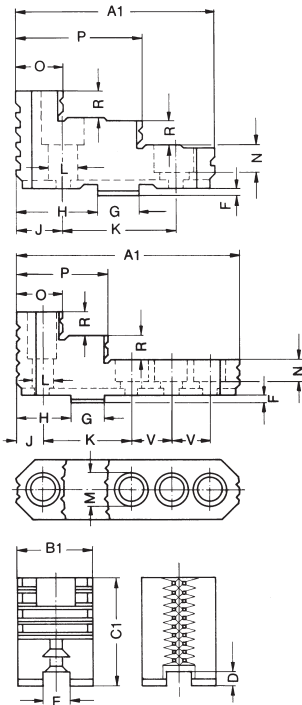

Chuck Size		100 110	125	140 160	200 230	250 270	315	350 400	500 630	700 800	1000 1250
A	1	47	56	66,7	79,5	95,3	109,5	127	127	210	210
	2	53	62	74	87	103	120	137	140	210	210
B	1	22	26	28	30	36	42	42	50	68	68
	2	22,5	26,5	28,5	30,5	36,5	42,5	42,5	50,5	68	68
C	1	29,5	37,5	41,5	42,5	52,5	57,5	64,5	79,5	89	110
	2	30	38	42	43	53	58	65	80	89	110
D		5,5	7,6	7,6	7,6	7,6	7,6	10,8	10,8	10,8	10,8
E		7,96	7,96	7,96	7,96	12,72	12,72	12,72	12,72	12,72	12,72
F		2,5	3,1	3,1	3,1	3,1	3,1	6,35	6,35	6,35	6,35
G		9,50	12,68	12,68	12,68	19,03	19,03	19,03	19,03	19,03	19,03
H		19,25	22,6	28,5	34,9	39,7	47,6	57,1	57,1	57,1	57,1
J		12	13	15,8	19	22,2	25,4	28,5	28,5	28,5	28,5
K		24	32	38,1	44,45	53,95	63,5	76,2	76,2	76,2	76,2
L		6,6	9	9 ¹⁾ 10,5 ²⁾	9 ¹⁾ 10,5 ²⁾	14	14	18	22	22	22
M		11	15	15 ¹⁾ 16 ²⁾	15 ¹⁾ 16 ²⁾	20	20	26	33	33	33
N		7	9	10	10	13,5	13,5	17	21	21,5	21,5
O		12	13	15,8	19	22,2	25,4	28,5	54,6	51	51
P		29,5	35	42,8	51,5	60,2	67,4	77	88,5	89	89
R		6	8	10	10	14	15	15	20	22	25
S		22,25	25,6	32,2	38,7	43,5	52,9	62,1	63,6	70	70
T		15	16	19,5	22,8	26	30,7	33,55	35	41,5	41,5
U		19	27	30	30	41	43	47	61	65	71
V		-	-	-	-	-	-	-	-	38,1	38,1
Jaw approx. kg	UB	0,12	0,19	0,27	0,39	0,66	1,02	1,27	2	4,45	6,1
	AB	0,21	0,34	0,5	0,7	1,2	1,86	2,18	3,04	8	10,8

Saw-tooth standard model

Cross-grooving from size 250 available from size 700 standard-model

Unstepped top jaw soft AB

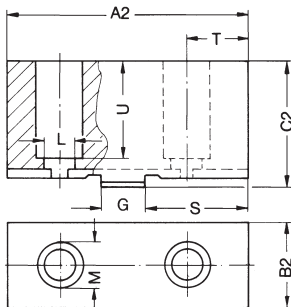

Special-design jaws

For non-rotating clamping devices, for symmetrical components, for machine vices and NC-compact vices available in all desired modifications.





Notes

Notes